

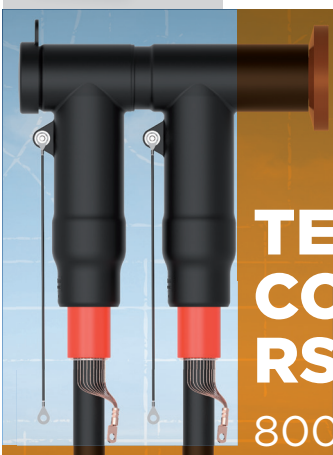

**CLIQUE E FAÇA  
SEU ORÇAMENTO !**

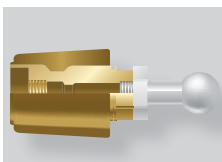

# TE'S RAYCHEM SCREENED COUPLING CONNECTORS RSTI-CC-68

800A up to 42 kV

**Product Features:**

- The screened coupling connector is designed to mate with the rear end of the RSTI-68 base screened connector system designed up to 42 kV
- The insulation of the coupling connector is made of a highly modified silicone rubber characterised by high tracking resistance, elongation at break and non-flammability
- A thin-walled screen is permanently bonded onto the insulation and protects the connection system against accidental contact
- The screened coupling connector need not be removed for overshield testing
- The combination of screened connector and coupling connector exceeds CENELEC HD 629.1 S1 requirements, which include BS, VDE and other international specifications
- Design of combination fits 630A and 1250A bushings (Interface “C1” and “C2”) as specified by EN 50180 and EN 50181
- The compact design supports the use of double «T» connections inside standard terminal boxes
- The wide application range covers cable cross-sections from 25 mm<sup>2</sup> to 300 mm<sup>2</sup>
- Conductor connection with mechanical or DIN lugs
- Easily accessible rear plug with capacitive test point
- Few accessories required for system test and earth connection
- Complete kit including lugs for easier installation and storage

**Design and construction:**

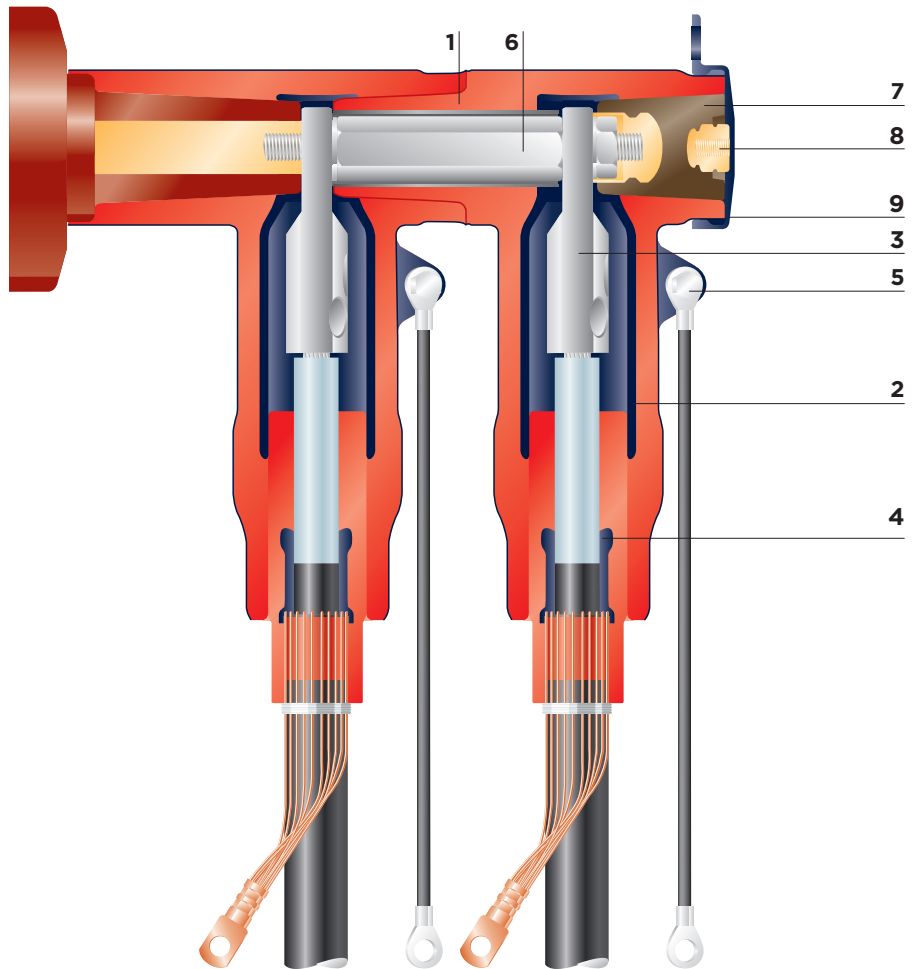

**1. Screened body**

A thin-walled conductive outer screen is permanently bonded to the silicone rubber insulating material of the body.

**2. Inner screen**

A conductive inner layer, as a faraday cage around the compression or mechanical lug, prevents corona at rated voltage.

**3. Compression or mechanical lugs**

Specially designed DIN compression lugs, as well as tinned, mechanical lugs with shear bolts for connecting either aluminium or copper conductor cables.

**4. Stress cone adapter**

Relieves electrical stress at the point where the cable screen is cut. The insulated section, extending beyond the wire shielding, provides a convenient point for overshield testing.

**5. Earthing eye and ground lead**

Provides a connection point for earthing the screen.

**6. Threaded pin assembly**

A threaded pin assembly together with a spring washer and hex nut ensure high-performance electrical and mechanical contact with the bushing.

**7. Rear plug with test point**

Removable rear plug with capacitive test point.

**8. Test point**

The test point is used to determine whether the circuit is energised; alternatively it can be used for phasing.

**9. Conductive end cap**

Electrical screen and protection of the rear end of the separable connector.

## Applications

### DOUBLE CONNECTION

Items required for 3 phases:  
1 x RSTI-68xx (Basic kit)  
1 x RSTI-CC-68xx (Coupling connector kit)

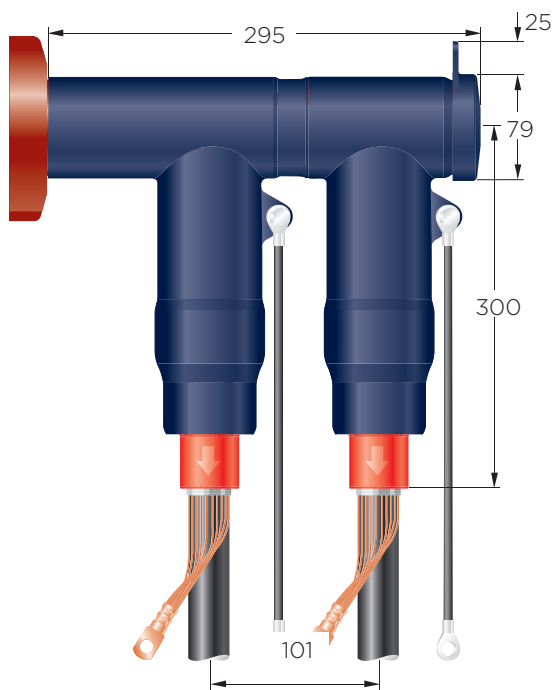

### SINGLE CORE BRANCH OFF

Items required for 3 phases:  
1 x RSTI-68xx (Basic kit)  
1 x RSTI-68TP (Terminating plug kit)  
2 x RSTI-CC-68xx (Coupling connector kit)

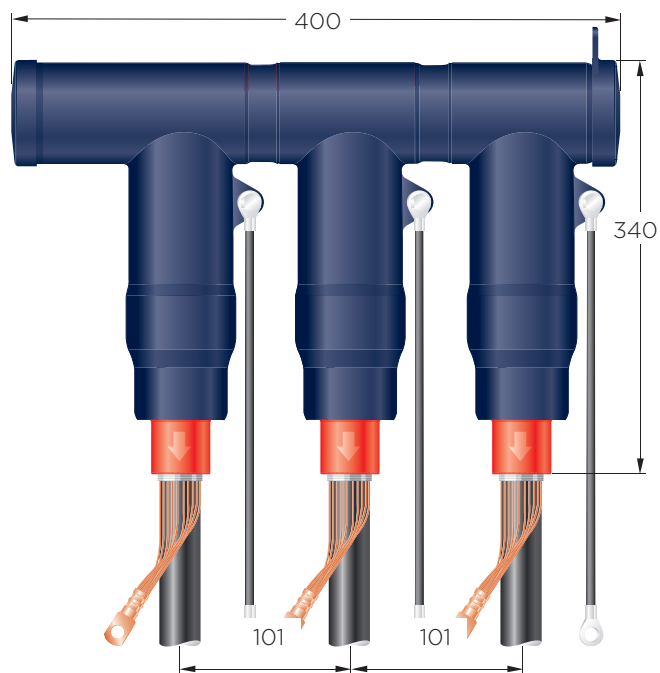

## Accessories

### TEST ROD

Ref. no.: RSTI-68TR; Length: 310 mm  
RSTI-68TRL; Length: 460 mm  
RSTI-68TRA; Kit includes  
2 short and 1 long test rod



### TERMINATING PLUG

Ref. no.: RSTI-68TP

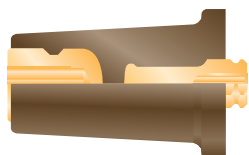

### INSULATING CAP

Ref. no.: RSTI-68RC  
One piece per set



### DISCONNECTABLE INLINE JOINT

Items required for 3 phases:  
1 x RSTI-68xx (Basic kit)  
1 x RSTI-68TP (Terminating plug kit)  
1 x RSTI-CC-68xx (Coupling connector kit)

**Note:** All applications as shown in the brochure need to have a mechanical support, based on the requirements for dynamic short circuit.

### EARTHING ADAPTER

Ref. no.: RSTI-68EA20;  
Ball diameter: 20 mm  
RSTI-68EA25;  
Ball diameter: 25 mm

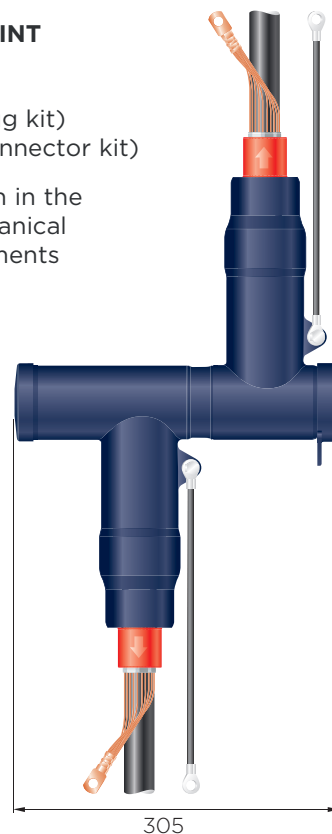
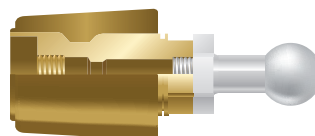

**TECHNICAL DATA FOR RSTI-CC-68**

Cable insulation diameter range	22.4 mm - 42.0 mm
Connector cross-section range	25 mm <sup>2</sup> - 300 mm <sup>2</sup>
Maximum system voltage	42 kV
Continuous current rating	800A
Basic impulse level	200 kV
Partial discharge at 2 U <sub>0</sub>	< 2 pC
AC voltage withstand, 5 min	93.5 kV
DC voltage withstand, 15 min	125 kV
Thermal short circuit, 1 s	55 kA
Thermal short circuit, 3 s	32 kA
Dynamic short circuit	125 kA

The adapters meet the international CENELEC HD 629.1 S2 specification.

**SELECTION TABLE**

**SCREENED SEPARABLE COUPLING CONNECTION SYSTEM 36 kV AND 42 kV WITH DIN COMPRESSION LUGS**

Cross Section (mm <sup>2</sup> )	Diameter Core Insulation (mm)		Reference Number Conductor Material	
	MIN	MAX	AL	CU
50	22.4	35.5	RSTI-CC-6811	RSTI-CC-6821
70	22.4	35.5	RSTI-CC-6812	RSTI-CC-6822
95	22.4	35.5	RSTI-CC-6813	RSTI-CC-6823
120	22.4	35.5	RSTI-CC-6814	RSTI-CC-6824
150	28.9	42.0	RSTI-CC-6815	RSTI-CC-6825
185	28.9	42.0	RSTI-CC-6816	RSTI-CC-6826
240	28.9	42.0	RSTI-CC-6817	RSTI-CC-6827
300	28.9	42.0	RSTI-CC-6818	RSTI-CC-6828

Kits including deep indent compression lugs on request. Contact your local sales representative.

**SCREENED SEPARABLE COUPLING CONNECTION SYSTEM 36 kV AND 42 kV WITH MECHANICAL LUGS AND SHEAR BOLTS**

Cross Section (mm <sup>2</sup> )	Diameter Core Insulation (mm)		Reference Number Conductor Material
	MIN	MAX	AL or CU
25 - 95	22.4	35.5	RSTI-CC-6851
95 - 120	22.4	35.5	RSTI-CC-6852
150 - 240	28.9	42.0	RSTI-CC-6853
300	28.9	42.0	RSTI-CC-6855

Kits for 3-core applications on request. Contact your local sales representative.

[te.com/energy](http://te.com/energy)

©2021 TE Connectivity Ltd. All Rights Reserved. EPP-1756-02-21

TE Connectivity, TE connectivity (logo), EVERY CONNECTION COUNTS, AMP, AMPACT, Bowthorpe EMP, Crompton Instruments, Raychem, SIMEL, UTILUX are trademarks. Other logos, product and Company names mentioned herein may be trademarks of their respective owners. While TE has made every reasonable effort to ensure the accuracy of the information in this brochure, TE does not guarantee that it is error-free, nor does TE make any other representation, warranty or guarantee that the information is accurate, correct, reliable or current. TE reserves the right to make any adjustments to the information contained herein at any time without notice. TE expressly disclaims all implied warranties regarding the information contained herein, including, but not limited to, any implied warranties of merchantability or fitness for a particular purpose. The dimensions in this brochure are for reference purposes only and are subject to change without notice. Specifications are subject to change without notice. Consult TE for the latest dimensions and design specifications.

**FOR MORE INFORMATION:  
TE Technical Support Centers**

USA/Canada:	+1 800-327-6996
Brazil:	+55 11-2103-6023
Mexico:	+52 55-1106-0800
South America:	+57 1-319-8962
Benelux:	+32 16-508-695
France:	+33 (0) 38-058-3210
Germany/Switzerland:	+49 (0) 89-608-9903
Italy:	+39 335-834-3453
Middle East/Africa:	+971 4-211-7020
Russia:	+7 495-790-790-2-200
Spain/Portugal:	+34 912-681-885
UK:	+44 08708-707-500
China:	+86 400-820-6015



## TE's Raychem Cable Accessories

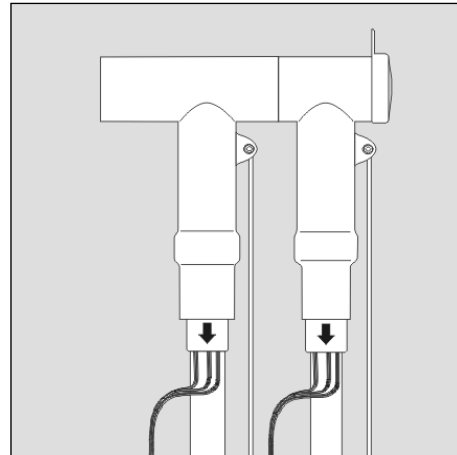

### Installation Instruction EPP-1769-4/16

**Raychem  
Screened Separable  
Coupling Connector 800 A for  
Fit onto Base Connector Type  
RSTI-68xx used with  
bushings Type "C"  
according to EN 50181  
and screened Single Core  
Polymeric Insulated Cable  
36 to 42 kV**

**Type: RSTI-CC-68xx**

#### **Safety Warning:**

**It is essential to observe the applicable safety regulations for working with high voltage equipment.**

**For precise safety information please contact the responsible authority.**

To view the TE Energy website:



**Tyco Electronics Raychem GmbH**  
a TE Connectivity Ltd. Company  
Finsinger Feld 1  
85521 Ottobrunn/Munich, Germany  
Tel: +49-89-6089-0  
Fax: +49-89-6096-345  
[TE.com/energy](http://TE.com/energy)

# Before Starting

Check to ensure that the kit you are going to use fits the cable.

Refer to the kit label and the title of the installation instruction.

Components or working steps may have been improved since you last installed this product.

Carefully read and follow the steps in the installation instruction.

## Kit Content

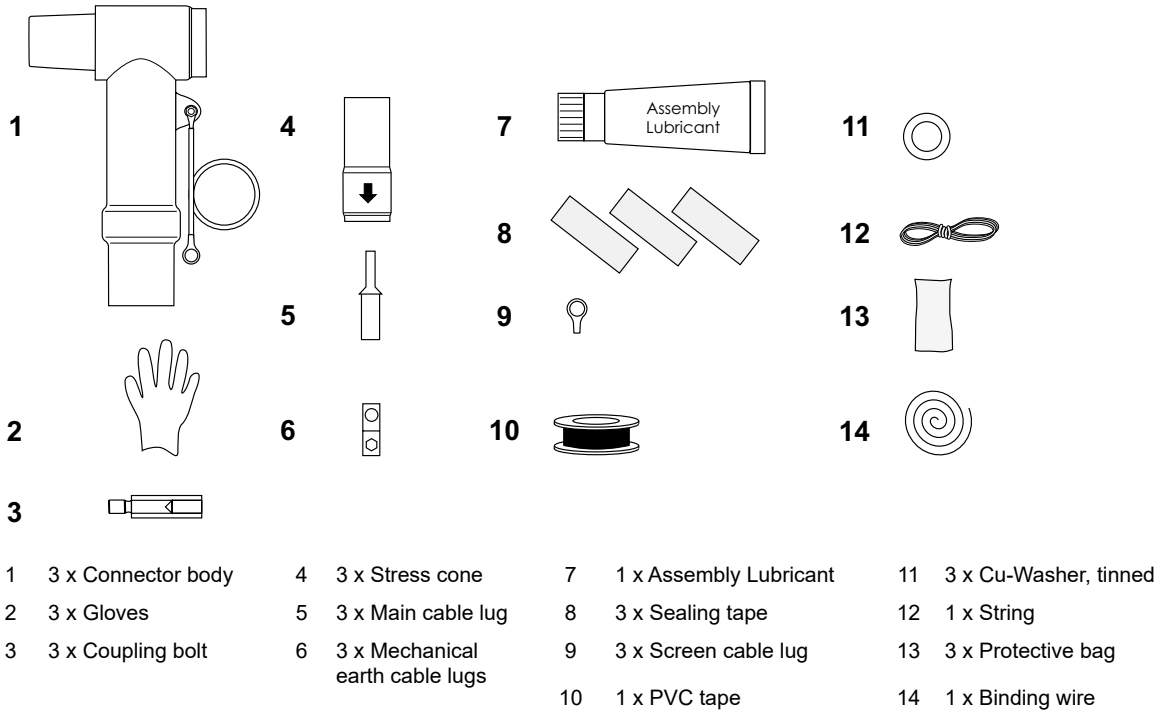

Table 1

Cross Section 36 & 42 kV	Ø Core Insulation		Reference No.		
	mm <sup>2</sup>	min	max	Al	Cu
50	22.4 – 35.5 mm			RSTI-CC-6811	RSTI-CC-6821
70				RSTI-CC-6812	RSTI-CC-6822
95				RSTI-CC-6813	RSTI-CC-6823
120				RSTI-CC-6814	RSTI-CC-6824
150	28.9 – 42.0 mm			RSTI-CC-6815	RSTI-CC-6825
185				RSTI-CC-6816	RSTI-CC-6826
240				RSTI-CC-6817	RSTI-CC-6827
300				RSTI-CC-6818	RSTI-CC-6828
35-95	22.4 – 35.5 mm			RSTI-CC-6851	
95-120				RSTI-CC-6852	
120-240	28.9 – 42.0 mm			RSTI-CC-6853	
185-300				RSTI-CC-6855	

The Information contained in these installation instructions is for use only by installers trained to make electrical power installations and is intended to describe the correct method of installation for this product. However, TE Connectivity has no control over the field conditions which influence product installation.

It is the user's responsibility to determine the suitability of the installation method in the user's field conditions. TE Connectivity's only obligations are those in TE Connectivity's standard Conditions of Sale for this product and in no case will TE Connectivity be liable for any other incidental, indirect or consequential damages arising from the use or misuse of the products.

Raychem, TE Connectivity and TE connectivity (logo) are trademarks.

© 2020 Tyco Electronics Raychem GmbH.

## Cable Preparation

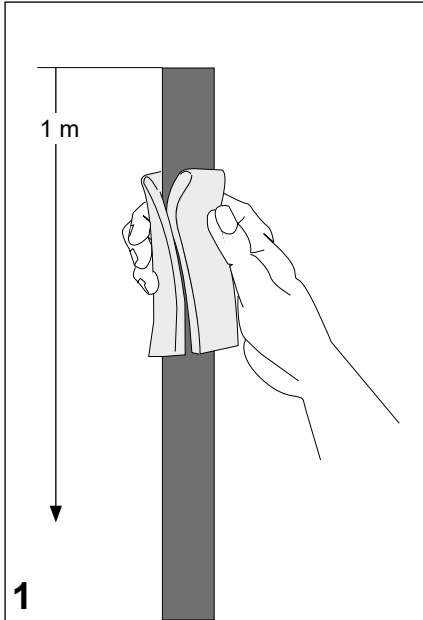

**1**  
Clean and degrease the end of the oversheath for a length of 1 metre with solvent wipe.

Cut the core according to dimensions provided with the drawing. Remove the core screen with appropriate screen cutting tool according to dimensions given in the drawing. The surface of the insulation should be free from all traces of conductive material.

Smooth out any irregularities.

**Note:** Do not nick the insulation.

Compare the diameter over insulation with application range as shown in **Table 1** as well as with marking of supplied stress cone.

### Application check!

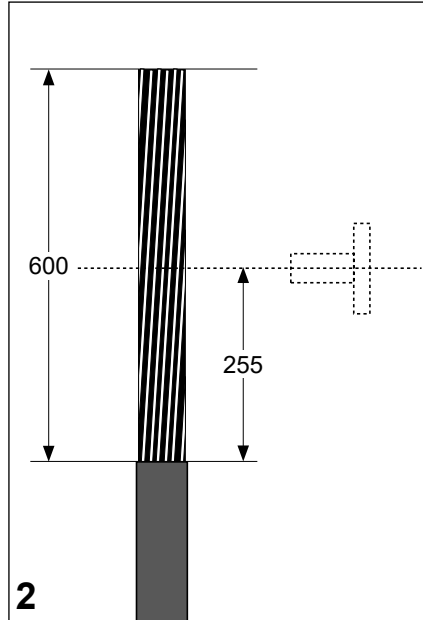
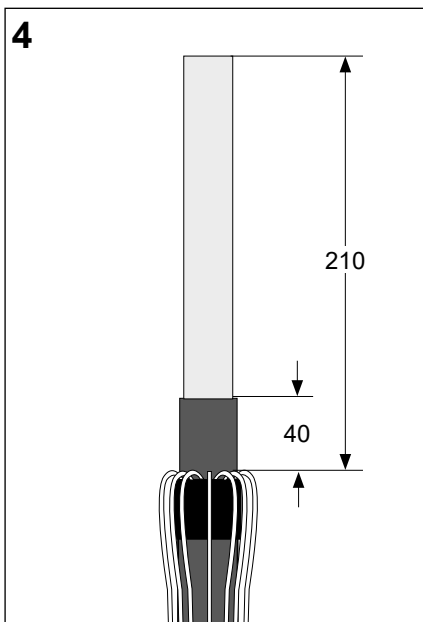

### Cable with wire shield

Position the cable with sufficient overlap to the bushing centre.

Mark the oversheath 255 mm below the bushing centre.

Cut the cable 600 mm above the mark and remove the oversheath over this distance. Cut off Cu-spiral screening tape flush with end of outer sheath.

**Edges** projecting beyond the outer sheath **must be avoided**, so that the stress cone can not be damaged during push on procedure.

Cut back the insulation according to dimension **K** given in drawing details.

### A. Compression technology (deep indentation and hexagonal)

Dimension **K** must not exceed 60 mm.

### B. Mechanical lugs

Dimension **K** is identical to bore depth. Barrel of lug butts against insulation.

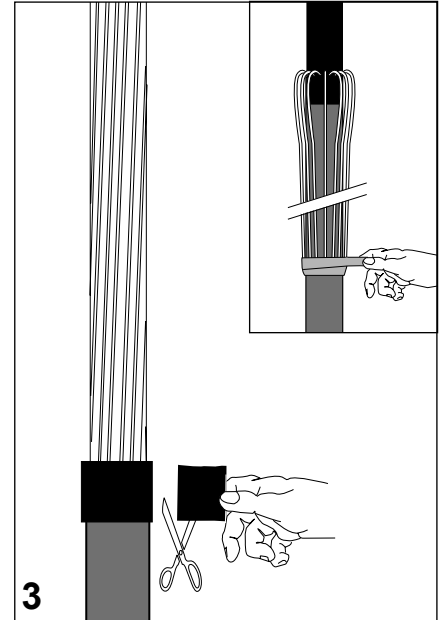
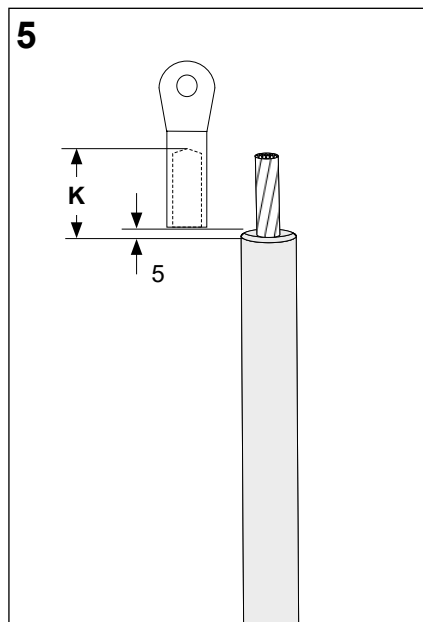

**3**  
Wrap one turn of sealant tape (grey) with no overlap and slight tension around the end of the oversheath.

Cut the tape and push ends together.

Bend the shielding wires back onto the oversheath.

Avoid crossing the individual wires.

Temporarily secure the wires with a tape or wire binder (see detail).

### Recommendation for large cross sections

Convenient push on process of the stress cone requires chamfering of the insulation for cross section  $\geq 240 \text{ mm}^2$  and above. See drawing!

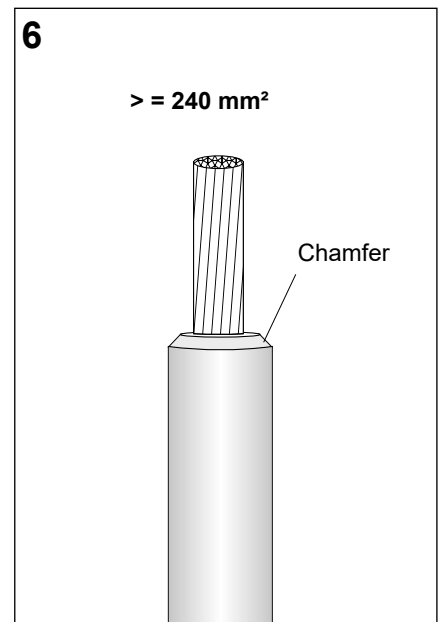

**Core Preparation**

**Table 2 - Use of Insert**

Cross Section Stranded mm <sup>2</sup> (RM)	Lug Type		
	BLMC-25/95-16-800A	BLMC-95/240-16-800A	BLMC-185/300-16-800A
35	YES		-
50	YES		-
70	NO		-
95	NO	YES	-
120	-	YES	-
150	-	YES	-
185	-	NO	YES
240	-	NO	YES
300	-	-	NO

**A. Compression Lugs**

Install the cable lug with the appropriate die and compression tool.

**Note:** Remove any sharp edges.

Clean and degrease the lug and insulation from any excessive compression grease.

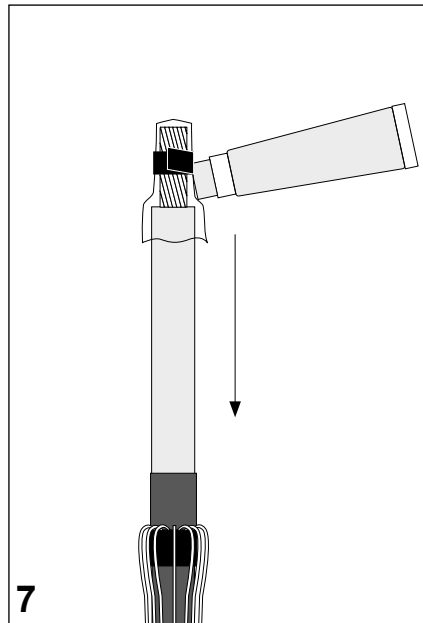
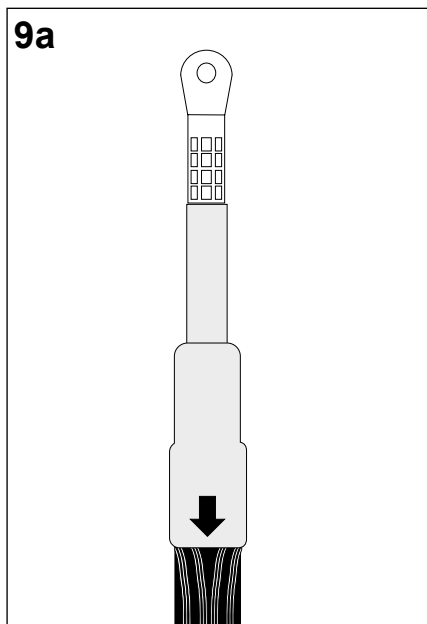

Slide the small protective bag (assembly aid) over the exposed conductor and tie it down with a PVC tape as shown in the drawing.

Gently lubricate the outer surface of the protective bag and the core insulation with a thin layer of assembly lubricant. Apply the lubricant layer with the sponge top as shown.

**B. Mechanical Lugs with Inserts**

The insert has to be used as noted in **Table 2**.

Ensure that the retention of the insert is locked into the appropriate slot in the barrel.

Install the cable lug using a lug fixture. Tighten the bolt set alternately in several equal steps until the heads shear off.

**Remove any sharp edges.**

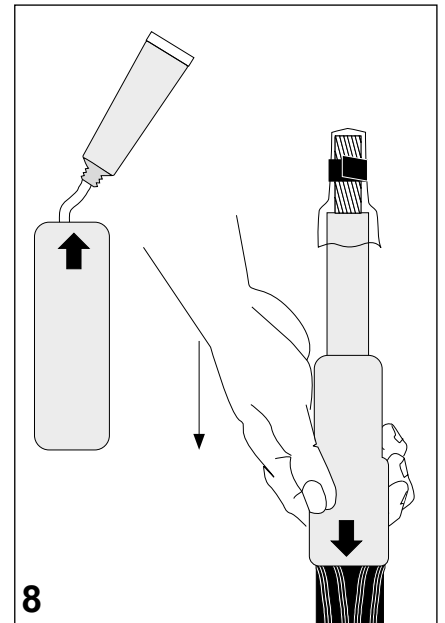
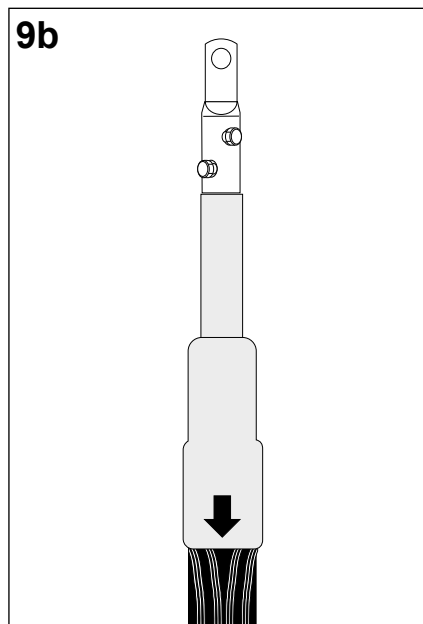

Apply onto the inner surface of the stress cone at the bottom end a 3 cm long sausage of assembly lubricant and spread it evenly over the inner surface. Use assembly lubricant without sponge top. Push the stress cone in one sequence with a twisting movement over the assembly aid completely onto the insulation until the inner collar of the stress cone stops at the oversheath cut back of the cable.

**Note:** The arrow on the stress cone should point onto the cable sheath.

Remove the assembly aid from the conductor.

Apply a thin layer of lubricant onto the outer surface of the stress cone with the sponge top.

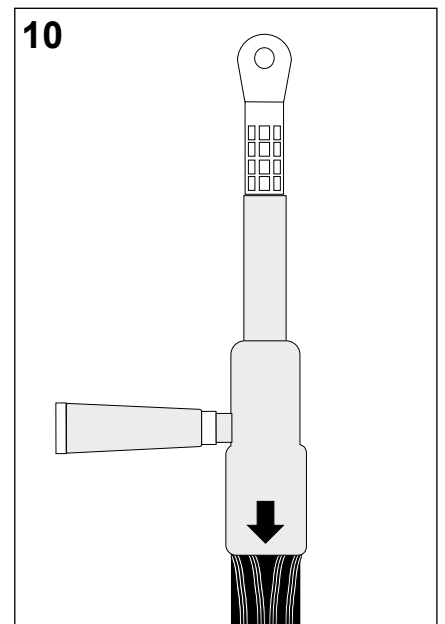



## Preparation of Installed Screened Separable Connector

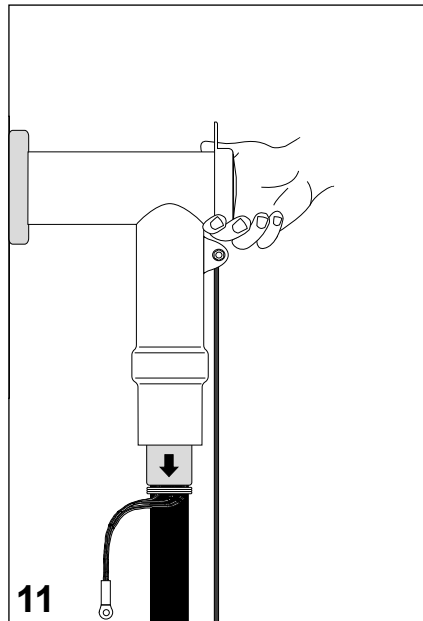

11 Remove from the installed connector the conductive endcap and save it in a clean container.

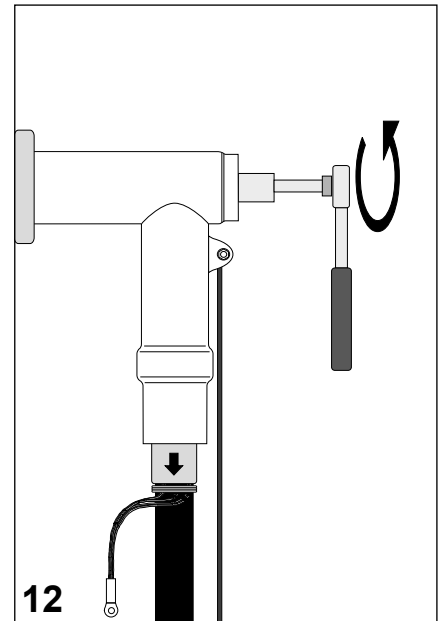

12 Remove from the installed connector the back plug and save it in a clean container.

## Installation of Coupling Connector

Remove from the installed connector **hexagon nut, washer, threaded pin** and save it in a clean container.

Ensure that the rear end of the already installed connector is lubricated with a thin layer of assembly lubricant.

Insert coupling stud with tinned Cu-washer (see detail) into the rear end of the connector and tighten it up with a torque wrench (27 mm).

Maximum torque: **35 Nm**.

Insert the **threaded stud M16** into the rear end of the coupling stud and tighten it up with an Allen key (8 mm). Maximum torque: **30 Nm**.

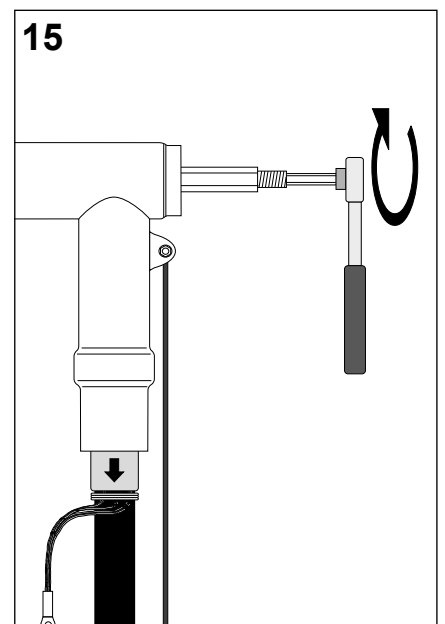
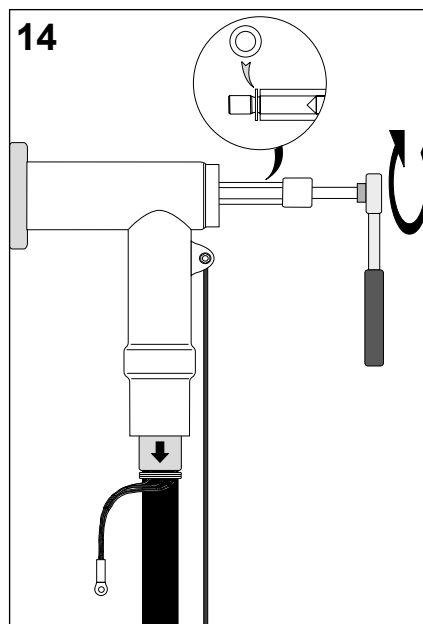
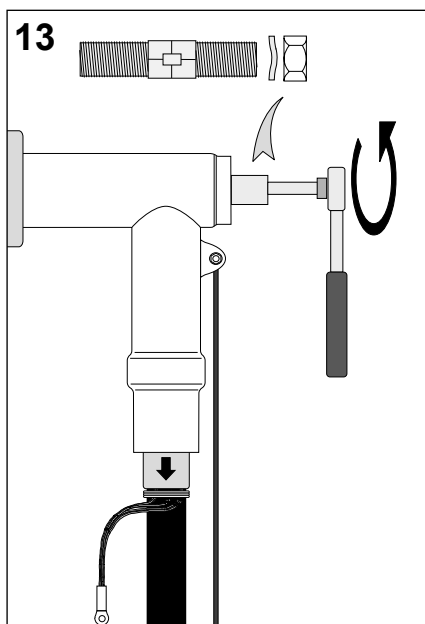

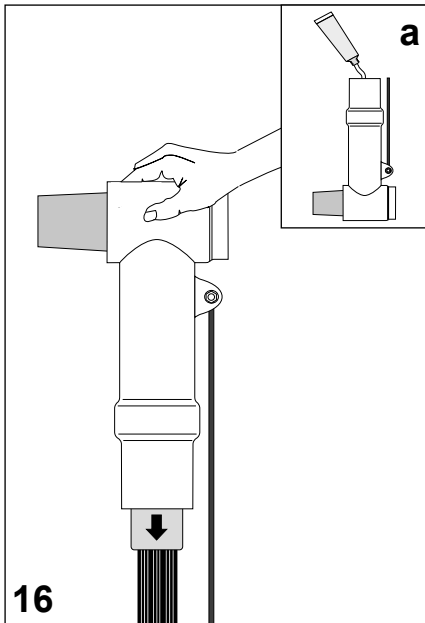

Clean the coupling connector body at the bottom end and apply a thin layer of lubricant onto the inner surface without the sponge top as shown in detail a.

**Note:** Use one way glove to evenly lubricate the inner surface at a length of approx. 50 mm.

Push the coupling connector body with no interruption onto the stress cone and hold it.

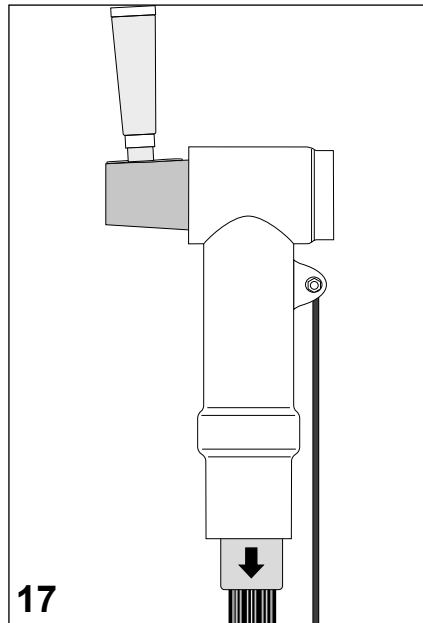

Clean the conical front end of the coupling connector and apply a thin layer of lubricant onto the outer surface of the cone with the sponge top. Continue **immediately** with the next step.

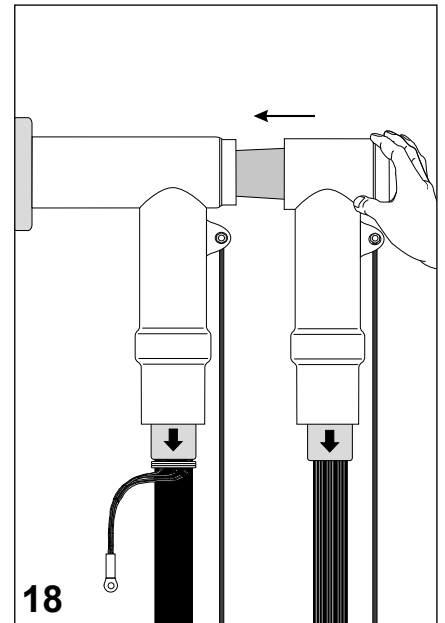

Align the conical front end of the coupling connector with the rear end of the already installed connector and push the coupling connector in position.

Insert the spring washer and hex nut. Tighten the hex nut onto the stud with a torque wrench (24 mm) at a torque of **30 Nm**.

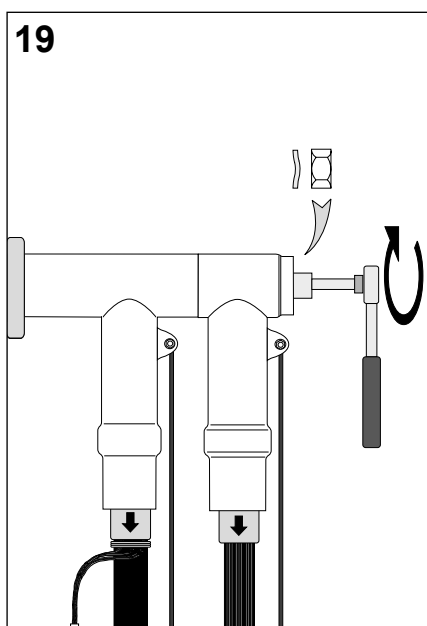

Clean the inner surface of connector back end and apply a thin layer of assembly lubricant. Do the same with the conical interface of the back plug as shown in detail.

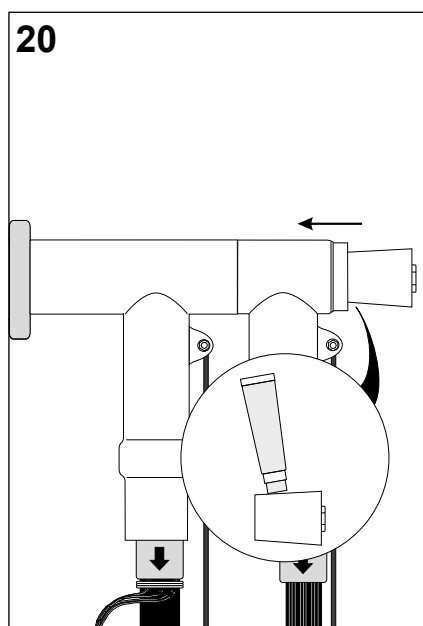

- a. Place a string into the rear entry of the connector as shown.
- b. Insert the back plug and screw it into place using a spanner (19 mm) at a torque of **30 Nm**.

Remove the string prior to the last two turns.

**Note:** Back plug has to be flush with connector end. In case of protrusion of back plug check steps 13 - 15 for correct installation of components.

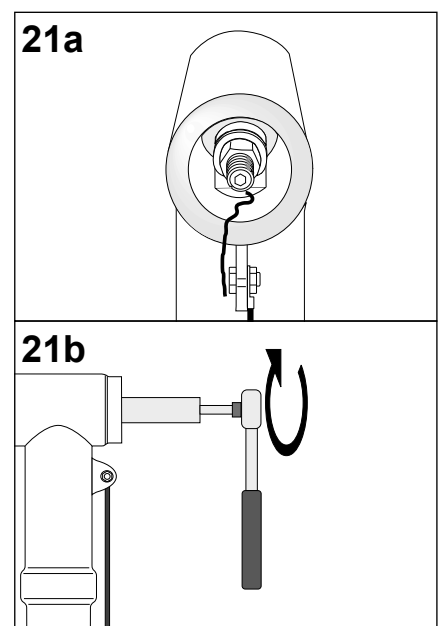

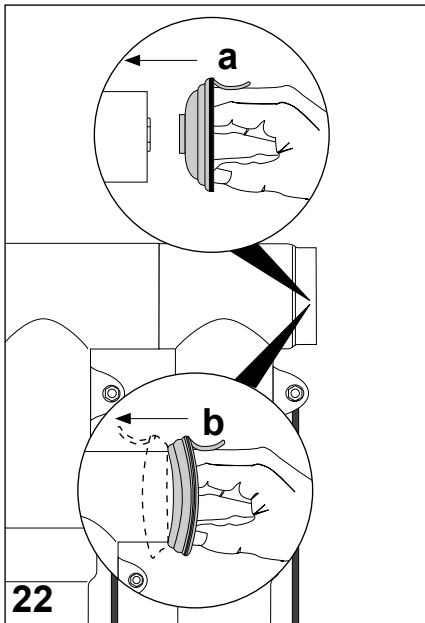

- a. Flip-back the endcap as shown in detail **a**. Position the protruding ring onto test point.
- b. Flip the endcap into final position with your finger as shown in detail **b**.

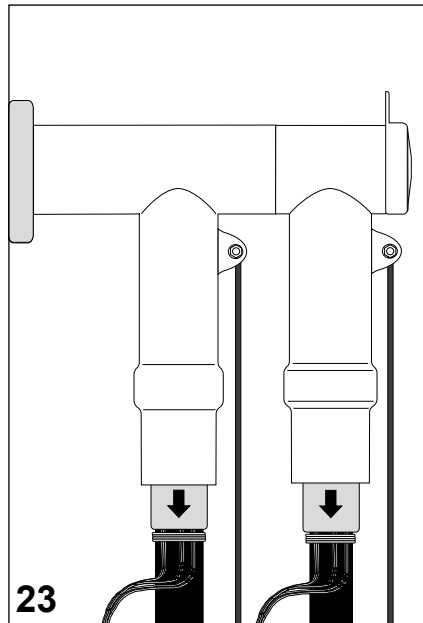

Ensure that the grounding lead is fastened tightly.

Fix the shielding wires with a wire binder (four layers) at the end of the stress cone.

Gather the wires together to form an earth lead. Install at the end of the shielding wires the connection lugs supplied in the kit.

**Perform connection to ground.**

Note: Ensure that each cable is fixed with suitable cable cleats onto cable rack at a distance of 400 mm from the center of the bushing.

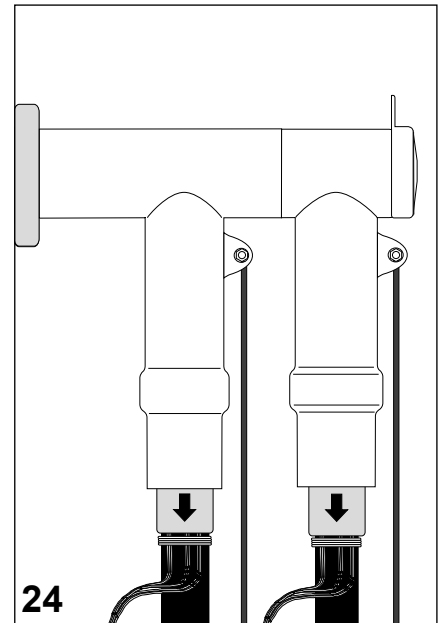

**Screened separable coupling connector completed.**

**Please dispose of all waste according to environmental regulations.**

