

Medium Voltage Distribution

# SF circuit breakers

up to 40.5 kV  
fixed and withdrawable versions

Catalogue  
2014

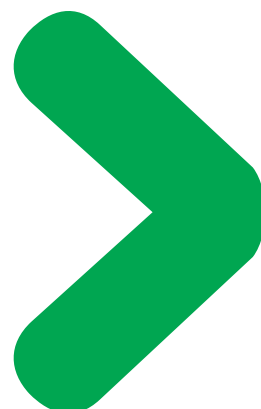

# SF circuit breakers

One range of comprehensive and proven three-pole circuit breaker units for indoor installation using SF6 technology. Both compact and dependable, it is ideally suited to the most demanding applications. This circuit breaker range meets IEC standard 62271-100.

**SF1 circuit breakers fixed version from 12 kV to 36 kV**



**SF2 circuit breakers fixed version from 24 kV to 40.5 kV**



**SF F400 circuit breakers withdrawable version from 24 kV to 40.5 kV**

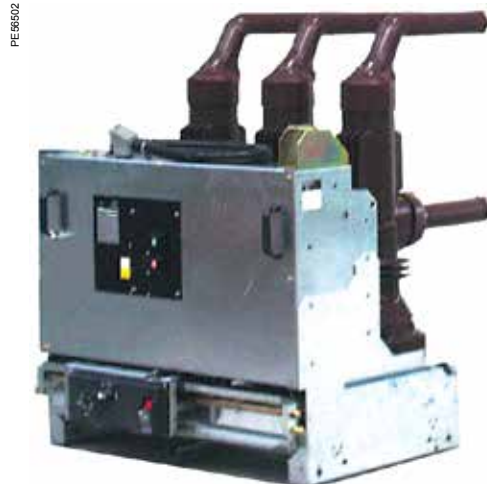

# General contents

---

General presentation	2	
----------------------	---	---

---

Panorama	5	
----------	---	---

---

SF1 and SFset circuit breakers fixed version	7	
---	---	---

---

SF2 circuit breakers fixed version	25	
---------------------------------------	----	---

---

SF F400 circuit breakers withdrawable version	35	
--	----	---

---

With over 37 years' industrial experience in SF6 techniques and over 300,000 installed devices throughout the world, Schneider Electric is today one of the foremost manufacturers of SF6 switchgear. Schneider Electric has developed a wide range of high performance and reliable devices operating faultlessly on all 5 continents. Continuously increasing its performance, the company maintains a very high level of innovation in its offer.

610511



### Safety

The breaking medium is sulfur hexafluoride (SF6) used at low pressure. The insulating enclosure containing the circuit breaker pole(s) is equipped with a safety membrane. In addition, the rated characteristics, breaking the rated current under the rated voltage, are generally maintained at zero relative bars of SF6.

### Reliability

The motor-charged spring stored energy operating mechanism is a key factor of device reliability: Schneider Electric cumulates 37 years' experience with this type of mechanism, 300,000 of which are already in operation. Schneider Electric's mastery of design and the testing of sealed systems guarantees sustained device performance for at least 30 years.

### Increased endurance

The mechanical and electrical endurance of Schneider Electric SF6 breaking devices are in conformity with the most demanding specifications recommended by the IEC. These devices therefore meet requirements for even the most exposed of networks.

### Less maintenance

Throughout the device's service life, which in normal operating conditions may be at least 30 years, the only maintenance required is on the mechanical operating mechanism, once every 10 years or every 10,000 operations. Although no maintenance is performed on poles, a diagnosis is possible:

- contact wear can be checked by external pole measurement
- SF6 pressure can be continually monitored by a pressure switch.

### Environmentally-friendly

Schneider Electric devices have been designed to ensure protection of the environment:

- the materials used, both insulating and conductive, are identified and easy to separate and recycle
- the SF6 gas is under control from production through to the circuit breaker's end of life. In particular it can be recovered at the end of the circuit breaker's life and re-used after treatment in line with the new European directive
- an end of life manual for the product details procedures for dismantling and recycling components.

### Quality Assurance

During production, each circuit breaker undergoes systematic routine tests in order to check quality and conformity:

- pole sealing check
- checking the correct mechanical operation of the device,
- plus its associated locking mechanisms
- checking simultaneous closing of contacts
- checking power frequency insulation level
- checking main circuit resistance
- checking auxiliary circuit insulation
- checking auxiliary circuit electrical resistance
- checking switching speeds
- checking the switching cycle
- measuring the switching times.

The results are recorded on the test certificate for each device which is initialed by the quality control department.

### Certification

The quality system for the design and production of SF range circuit breakers is certified in conformity with ISO 9001: 2000 quality assurance standard requirements. The environmental management system adopted by Schneider Electric production sites for the production of SF range circuit breakers has been assessed and judged to be in conformity with requirements in standard ISO 14001.

DE55745



DE55746



# SF circuit breakers

## Breaking principle

### Breaking principle: puffer type

SF circuit breakers use the puffer principle with SF6 gas.

This method cools and extinguishes the electrical arc as it passes through zero current by puffing a gas compressed by a piston attached to the moving contact. The gas is channeled by an insulating nozzle towards the tubular arcing contacts that are used as an exhaust.

This breaking technique is used for high-performance breaking applications (40.5 kV-31.5 kA) and has been used for the past 37 years.

The operating sequence in a puffer-type breaking chamber with the moving part actuated by a control mechanism is as follows:

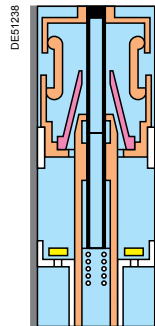

■ the circuit breaker is closed

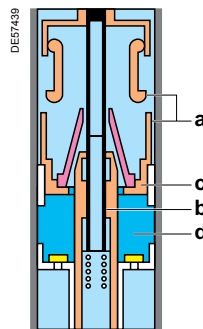

■ following an opening order the main contacts separate (a) and the current is directed into the breaking circuit (b). When the main contacts start to open the piston (c) slightly compresses the SF6 gas in the compression chamber (d)

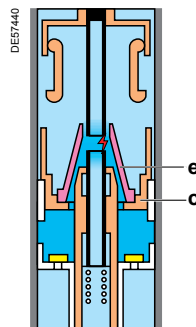

■ an electrical arc appears on separation of the arcing contacts. The piston (c) continues its travel downwards. A small quantity of the gas channeled by the insulating nozzle (e) is injected towards the arc. For low current breaking, the arc is cooled by forced ventilation. However, for high currents the thermal expansion moves the hot gases towards cooler parts in the breaking unit.

The distance between arcing contacts becomes sufficient to allow breaking of the current when it passes through zero due to the dielectric properties of the SF6 gas

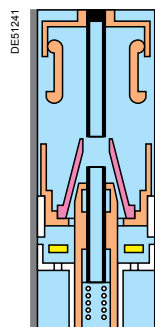

■ the moving parts finish their movement and injection of cold gas continues until the contacts are fully open. The circuit breaker is open.

## Circuit breakers

### SF range circuit breakers

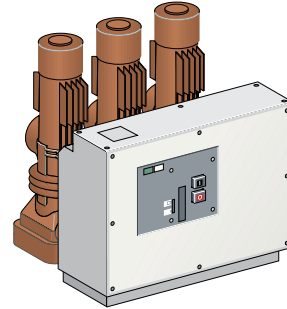
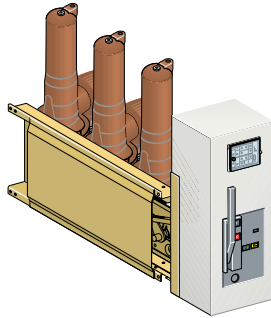
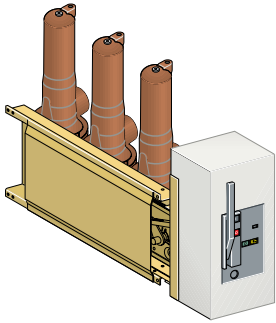

#### SF1 fixed

Side or front operating mechanism

Rated voltage  $U_r$  (kV, 50/60 Hz)

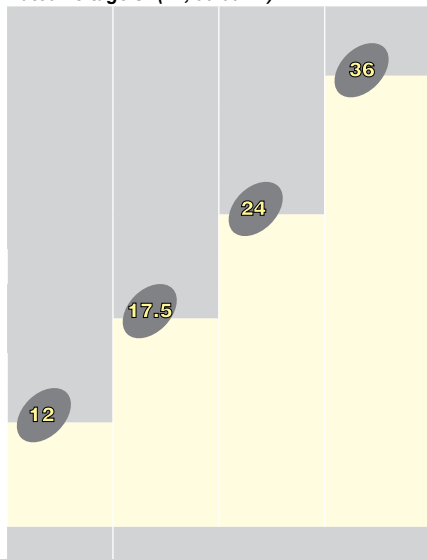

Rated short-circuit breaking current ( $I_{sc}$ )

25 kA    from 12.5 to 25 kA

Rated current ( $I_r$ )

630 A    from 400 to 1250 A

#### SFset fixed

Side or front operating mechanism with integrated VIP

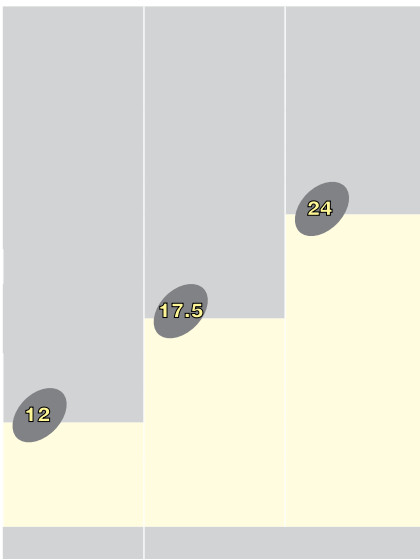

25 kA    from 12.5 to 25 kA

630 A    from 400 to 1250 A

#### SF2 fixed

Front operating mechanism

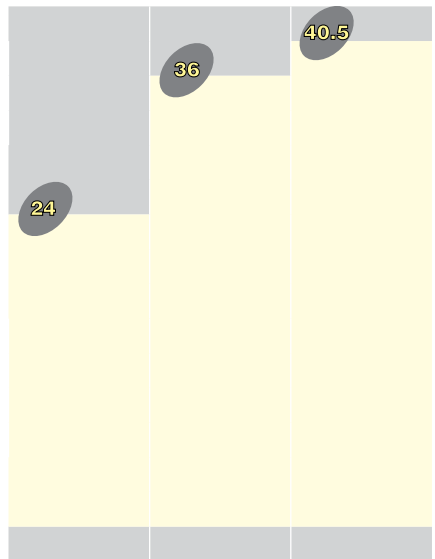

from 12.5 to 40 kA    from 25 to 40 kA    31.5 kA

from 630 to 3150 A    2500 A

## Protection, monitoring and control

### SFset circuit breakers

### SF1/SF2/SF F400 C. B.

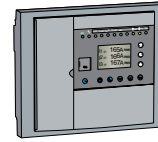
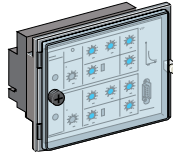
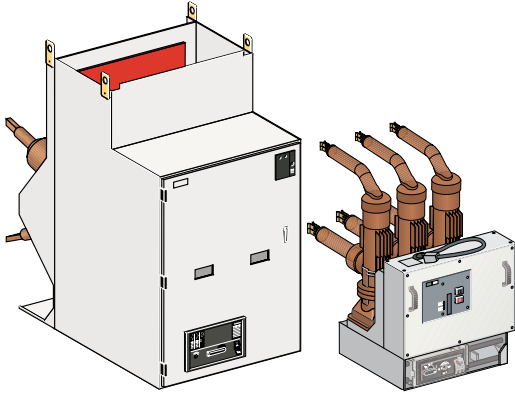

#### SF F400 withdrawable Front operating mechanism

**VIP300P**  
for phase protection

**Sepam series 20**  
for normal applications

**VIP300LL**  
for phase and earthing protection

**Sepam series 40**  
for demanding applications

**Sepam series 80**  
for customized applications

36	40.5
from 25 to 40 kA	31.5 kA
1250 and 2500 A	1250 A

Separate catalogue



---

<b>Presentation</b>	<b>9</b>
<b>General characteristics</b>	<b>10</b>
<b>Description of functions</b>	<b>12</b>
RI stored energy operating mechanism	12
Wiring diagram	12
Opening circuit	13
Remote control	14
Indication and locking/interlocking	15
<b>Protection, monitoring and control</b>	<b>16</b>
VIP300 protection unit	16
Trip curves for VIP300P and VIP300LL	17
Current sensors and test unit for VIP300	18
<b>Dimensions</b>	<b>19</b>
<b>Order form</b>	<b>22</b>





SF1 circuit breakers with a B1 side operating mechanism



SFset circuit breakers with a B1 side operating mechanism

## Description of the device

### The basic withdrawable version of the SF circuit breaker comprises:

- 3 main independent poles, that are mechanically linked and each comprising a “sealed pressure system” type insulating enclosure. The sealed enclosure is filled with low pressure SF6 gas
- a stored energy operating mechanism of manual RI type (that can be electrically operated as an option)

This gives the device an opening and closing speed that is independent of the operator, for both electrical and manual orders.

When equipped with an electrical operating mechanism, the circuit breaker can be remotely controlled and it is possible to carry out reclosing cycles.

- a front panel housing the manual operating mechanism and status indicators
- upstream and downstream terminals for the power circuit connection
- a terminal block for connection of external auxiliary circuits.

According to its characteristics, the SF circuit breaker is available either in frontal version or in lateral version.

### Each device can be optionally equipped with:

- an electrical operating mechanism
- a support frame fitted with rollers and floor securing brackets for a fixed installation
- locking of the circuit breaker in the open position by a keylock installed on the control panel
- a pressure switch for the high performance versions
- a Harting 42-pin type LV connector.

### The SFset includes an independent protection chain

The SFset is provided with a fully autonomous integrated protection chain (with a VIP type control unit) operating without an auxiliary power source.

The VIP protection unit exists in two models: VIP300P and VIP300LL.

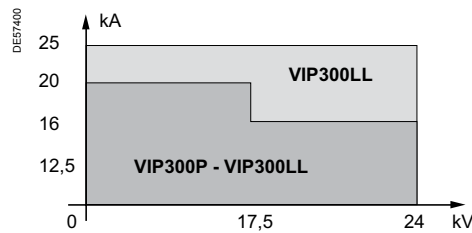

Depending on the model, the unit provides protection against phase over-currents and earthing faults.

VIP protection units are associated with functional current sensors.

Two interchangeable sensors, **CSa** and **CSb**, are sufficient to cover all requirements from 10 to 1250 A.

SFset is delivered equipped and cabled with its protection chain, this simplifies panel builders' installation work.

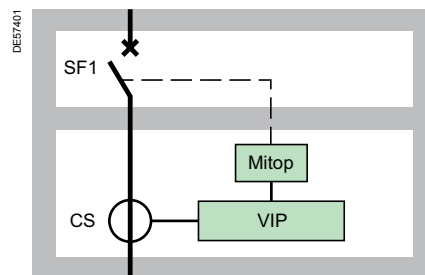

SFset schematic diagram

## Applications

SF circuit breakers are 3-pole MV circuit breakers for indoor installation.

They are mainly used for switching and protection of networks from 12 to 36 kV in primary and secondary power distribution.

Because the SFset protection chain is autonomous in terms of power, this circuit breaker is particularly suited to certain dispersed installations on the network.

The autocompression breaking technique used in these circuit breakers means that making or breaking all types of capacitive or inductive currents can be achieved without dangerous overvoltages for the switchgear connected to the network.

The SF circuit breaker is therefore well suited to operating capacitor banks.

## Electrical characteristics according to IEC 62271-100

### SF1



PEE66603

Rated voltage	<b>Ur</b>	kV 50/60 Hz	12	17.5				
Insulation voltage								
- power frequency withstand	<b>Ud</b>	kV 50 Hz 1min	28	38				
- lightning impulse withstand	<b>Up</b>	kV peak	75	95				
Rated current	<b>Ir</b>	A						
		400	–	–	■	–		
		630	■	■	■	■		
		1250	–	■	■	■		
Short circuit current	<b>Isc</b>	kA	25	12.5	20	25		
Short time withstand current	<b>Ik/tk</b>	kA/3 s	25	12.5	20	25		
Short-circuit making current	<b>Ip</b>	kA peak						
		50 Hz	62.5	31.3	50	62.5		
		60 Hz	65	32.5	52	65		
Rated switching sequence		O-3 min-CO-3 min-CO	■	■				
		O-0.3 s-CO-3 min-CO	■	■				
		O-0.3 s-CO-15 s-CO	■	■				
Phase to phase		mm						
		220	–	■	■	■		
		250	■	■	■	■		
		280	–	–	–	–		
		350	–	–	–	–		
		380	–	–	–	–		
Operating mechanism		A1 lateral (*)	–	■	■	■		
		B1 lateral (*)	–	■	■	■		
		C1 frontal (*)	–	■	■	■		
		For SM6 switchgear	■	–	■	–		
Operating times		Opening (ms)	< 50					
		Breaking (ms)	< 60					
		Closing (ms)	< 65					
Service temperature	<b>T</b>	°C	- 5 to + 40 (**)					
Mechanical endurance		Class	M2					
		Number of switching operations	10,000					
Electrical endurance		Class	E2					
Capacitive current breaking capacity		Class	C2					

■ Available

– Not available

(\*) See chapter "Dimensions".

(\*\*) For a temperature lower than -5 °C, please consult us

### Specific applications

#### Switching and protection of capacitor banks

SF range circuit breakers are particularly well suited to switching and protection of capacitor banks; they are classed C2 according to standard IEC 62271-100. Tests carried out according to the standard for breaking at 400 A with making and breaking cycles in case of a capacitor bank with a making current of 20 kA. Additional tests have been carried out: please consult us.

SFset



24				36				12				17.5				24			
50				70				28				38				50			
125				170				75				95				125			
■	■	-	-	■	-	-	-	-	-	■	-	■	-	■	-	■	-		
■	■	■	■	■	■	■	■	■	■	■	■	■	■	■	■	■	■		
■	■	■	■	■	■	■	■	-	■	■	■	■	■	■	■	■	■		
12.5	16	20	25	12.5	16	20	25	25	12.5	20	25	12.5	16	20	25	12.5	16	20	25
12.5	16	20	25	12.5	16	20	25	25	12.5	20	25	12.5	16	20	25	12.5	16	20	25
31.3	40	50	62.5	31.3	40	50	62.5	62.5	31.3	50	62.5	31.3	40	50	62.5	31.3	40	50	62.5
32.5	41.6	52	65	32.5	41.6	52	65	65	32.5	52	65	32.5	41.6	52	65	32.5	41.6	52	65
■	-	-	-	■	-	-	-	■	■	-	-	■	-	-	-	■	-	-	-
■	-	-	-	■	-	-	-	■	■	-	-	■	-	-	-	■	-	-	-
■	-	-	-	■	-	-	-	■	■	-	-	■	-	-	-	■	-	-	-
-	-	-	-	-	-	-	-	-	■	■	■	-	-	-	-	-	-	-	-
■	■	■	■	■	-	■	■	-	■	■	■	■	■	■	■	■	■	■	■
■	■	■	■	■	-	■	■	-	■	■	■	■	■	■	■	■	■	■	■
■	■	■	■	■	-	■	■	-	■	■	■	■	■	■	■	■	■	■	■
■	■	■	-	■	■	■	■	-	-	■	-	■	■	■	■	■	■	■	-
< 50				< 50				< 50				< 50							
< 60				< 60				< 60				< 60							
< 65				< 65				< 65				< 65							
- 5 to + 40(**)				- 5 to + 40(**)				- 5 to + 40(**)				- 5 to + 40(**)							
M2				M2				M2				M2							
10,000				10,000				10,000				10,000							
E2				E2				E2				E2							
C2				C2				C2				C2							

■ Available  
 - Not available  
 (\*) See chapter "Dimensions".  
 (\*\*) For a temperature lower than -5 °C, please consult us

# Description of functions

## RI stored energy operating mechanism

### Wiring diagram

PEE7164



#### Manual or electrical operation of the RI stored energy operating mechanism

This gives the device an opening and closing speed that is independent of the operator whether the order is electrical or manual.

The electrical control mechanism carries out reclosing cycles and is automatically recharged by a geared motor each time after closing.

#### It consists of:

- the stored energy operating mechanism which stores in springs the energy required to open and close the device
- a manual lever-operated spring arming device
- a geared electrical arming device which automatically re-arms the control mechanism as soon as the circuit breaker is closed (optional)
- manual order devices by push buttons on the front panel of the device
- an electrical remote closing device containing a release with an antipumping relay
- an electrical opening order device comprising one or several release units which can be of the following type:
  - shunt opening
  - undervoltage
  - Mitop, a low consumption release, used only with the Sepam 100 LA protection relay.
- an operation counter
- an "open/closed" position indicator device with a mechanical indicator
- a device for indicating "charged" operating mechanism status by mechanical indicator and electrical contact (optional)
- a module of 14 auxiliary contacts whose availability varies according to the diagram used.

#### Wiring diagram (principle)

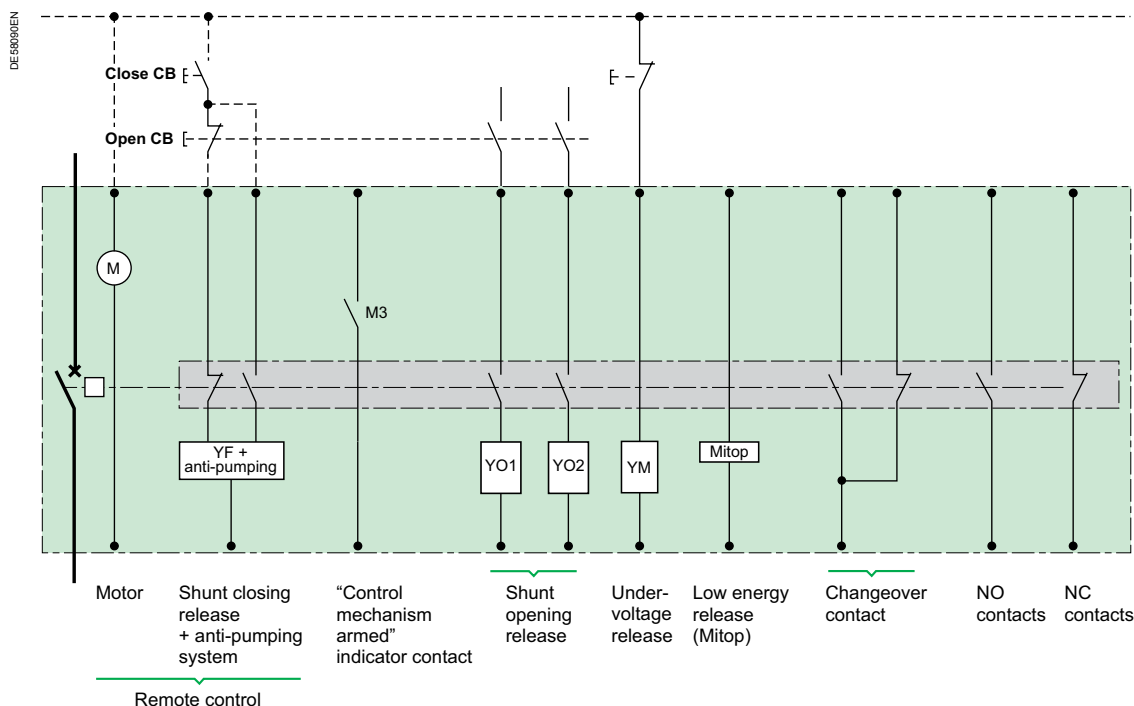

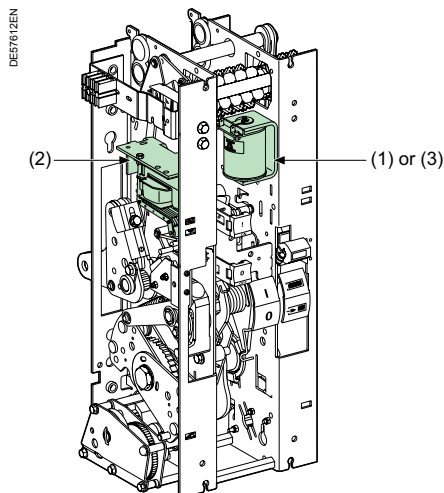

Operating mechanism

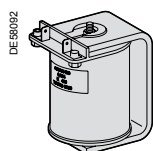

Shunt opening release (1)

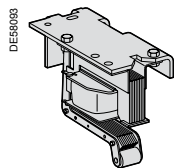

Undervoltage release (2)

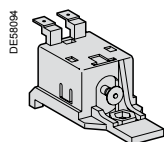

Low energy release (3)

### Composition

The opening circuit can be produced using the following components:

- a shunt opening release (on energizing) (YO1)
- a second shunt opening release (on energizing) (YO2)
- undervoltage release (YM)
- low energy release (Mitop).

**Note:** see the table of the releases' combinations page "Order form".

### Shunt opening release (YO1 and YO2)

Energizing this unit causes instant opening of the circuit breaker.

#### Characteristics

Power supply	See "Order form" page	
Threshold	V AC	0.85 to 1.1 Ur
	V DC	0.7 to 1.1 Ur
Consumption	V AC	160 VA
	V DC	50 W

### Undervoltage release (YM)

This release unit causes the systematic opening of the circuit breaker when its supply voltage drops below a value less than 35% of the rated voltage, even if this drop is slow and gradual. It can open the circuit breaker between 35% and 70% of its rated voltage. If the release unit is not supplied power, manual or electrical closing of the circuit breaker is impossible. Closing of the circuit breaker is compulsory when the supply voltage of the release unit reaches 85% of its rated voltage.

#### Characteristics

Power supply	See "Order form" page		
Threshold	Opening	0.35 to 0.7 Ur	
	Closing	0.85 Ur	
Consumption	Triggering	V AC	400 VA
		V DC	100 W
	Latched	V AC	100 VA
		V DC	10 W

### Low energy release (Mitop)

This specific release unit comprises a low consumption unit and is specifically used for Sepam 100LA self-powered relays.

#### Characteristics

Power supply	Direct current
Threshold	0.6 A < I < 3 A

Any tripping due to the Mitop release unit is momentarily indicated by an SDE type changeover contact (option).

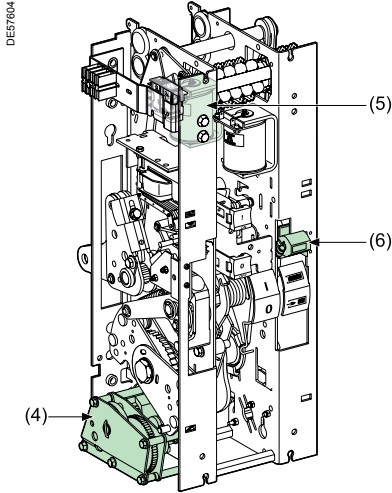

Operating mechanism

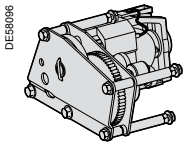

Electrical motor with gearing (4)

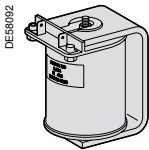

Shunt closing release (5)

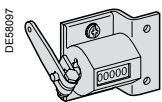

Operation counter (6)

### Function

Remote control enables the remote opening and closing of the circuit breaker.

### Composition

The remote control mechanism comprises:

- an electrical motor with gearing
- a shunt closing release (YF) combined with an anti-pumping device
- an operation counter.

### Electrical motor with gearing (M)

The electrical motor carries out the automatic rearming of the stored energy unit as soon as the circuit breaker is closed. This allows the instant reclosing of the device after opening. The arming lever is only used as a backup operating mechanism in the case of the absence of the auxiliary power supply. The M3 contact indicates the end of arming operations.

#### Characteristics

Power supply	See "Order form" page	
Threshold	V AC/V DC	0.85 to 1.1 Ur
Consumption	V AC	380 VA
	V DC	380 W

### Shunt closing release (YF)

This release allows the remote closing of the circuit breaker when the operating mechanism is armed.

#### Characteristics

Power supply	See "Order form" page	
Threshold	V AC	0.85 to 1.1 Ur
	V DC	0.85 to 1.1 Ur
Consumption	V AC	160 VA
	V DC	50 W

The shunt closing release is combined with an anti-pumping relay that enables priority to be given to opening in the case of a permanent closing order. This thus avoids the device being caught in an uncontrolled opening-closing cycle.

### Operation counter

The operation counter is visible on the front panel.

It displays the number of switching cycles (CO) that the device has carried out.

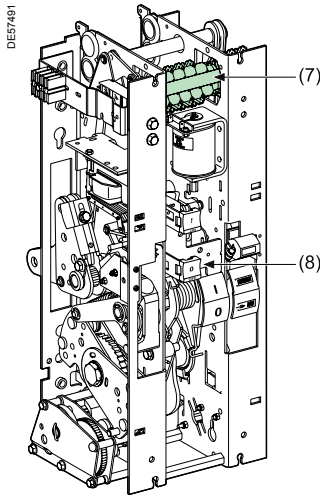

Operating mechanism



Auxiliary contacts (7)

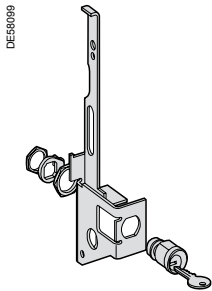

Keylocking kit (8)

### “Open/closed” auxiliary contacts

The number of contacts available depends on the options chosen on the operating mechanism.

In the basic configuration, the circuit breaker’s operating mechanism comprises a total of:

- 6 normally closed contacts (NC)
- 7 normally open contacts (NO)
- 1 changeover contact (CHG).

The usage procedure for auxiliary contacts is given in the following table:

Options	NC contact	NO contact
Remote control	1	1
Shunt opening release (each one) YO1/YO2	0	1
Undervoltage release YM	0	0
Low energy release (Mitop)	0	0

In order to know the final number of available contacts, you must deduct the total number of contacts included in the circuit breaker (6 NC + 7 NO + 1 CHG), the number of contacts used given in the table above.

**E.g.:** a circuit breaker equipped with a remote control and a shunt trip unit has the following available contacts:

6 NC + 5 NO + 1 CHG.

With a undervoltage release instead of the shunt trip, this circuit breaker would have the following available contacts:

6 NC + 6 NO + 1 CHG.

Shunt opening release combination				
	1st release	Shunt opening release YO1	Undervoltage release YM	Mitop
2nd release				
Without		6NC + 5NO + 1CHG	6NC + 6NO + 1CHG	6NC + 6NO + 1CHG
Shunt opening release YO2		6NC + 4NO + 1CHG		
Undervoltage release YM		6NC + 5NO + 1CHG		
Mitop		6NC + 5NO + 1CHG	6NC + 6NO + 1CHG	

### Locking the circuit breaker in the “open” position

This key-operated device allows the circuit breaker to be locked in the “open” position. The circuit breaker is locked in the open position by blocking the opening push button in the “engaged” position.

Locking is achieved using a Profalux or Ronis captive key type keylock.

PE69504



SFset with a VIP protection unit installed on the front panel

### The SFset circuit breaker has an integrated and independent protection system

The SFset circuit breaker comprises an SF1 into which is integrated a protection system comprising:

- a set of current sensors installed on the lower current terminals of the pole units. Two interchangeable sensors, **CSa** and **CSb**, sufficient to cover all requirements from 10 A to 1250 A.
  - a **VIP type protection relay** mounted on the control unit.
  - a **“Mitop” low consumption**, release unit installed on the switching device.
- The unit is fully independent and functions without an auxiliary power supply.

#### Operating principle

The protection system is supplied power by sensors which supply:

- the **“current” information**, processed by the protection unit
- the **electrical power** required for the whole protection system to operate ; VIP unit and Mitop release.

All settings are visible and accessible from the front of the device.

PE69772



VIP300LL protection unit

### VIP300P and VIP300LL independent protection unit

The VIP300 unit is intended to be installed on distribution networks. It can be used to protect an MV/LV transformer, to protect the head of an industrial installation, but also to protect a branch.

The VIP300 provides protection against phase-to-phase faults and against earthing faults. The choice of trip curves and the large number of settings enable it to be used in a large number of discrimination arrangements.

The VIP300 is an independent unit supplied power from the current sensors; it does not require an auxiliary power supply. It activates a Mitop release unit.

The VIP300 exists in 2 models:

- **VIP300P**: phase protection
- **VIP300LL**: phase and earthing protection.

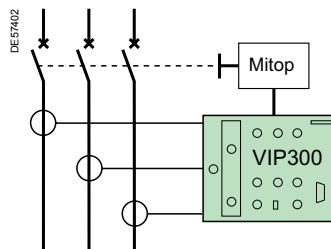

Simplified connection arrangement

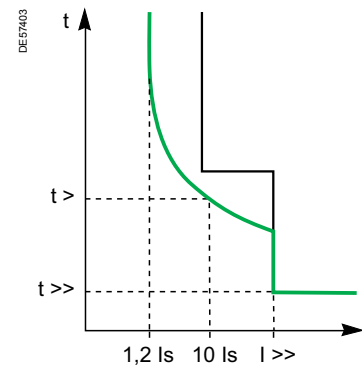

Phase and earthing protection curve

#### Phase protection (VIP300P, VIP300LL)

Phase protection has two independently adjustable thresholds:

- the lower threshold can be chosen to be either definite time or inverse definite time. It can be executed according to the RI curve.
  - the upper threshold is inverse definite time.
- The definite time curves are in conformity with standard IEC 60255-3. They are either of type inverse (SI), very inverse (VI) and extremely inverse (EI).

#### Earthing protection (VIP300LL)

Earthing full protection functions with the measurement of residual current: this is carried out based on the sum of secondary currents in the sensors.

As for phase protection, earthing protection has two independently adjustable thresholds.

#### Indication

Two indicators show the origin of the release (phase or earth).

They stay in position after breaking the release unit power supply.

Two LED indicator lights (phase and earth) show that the lower threshold has been exceeded and that the time delay has been started.

#### Trip curves

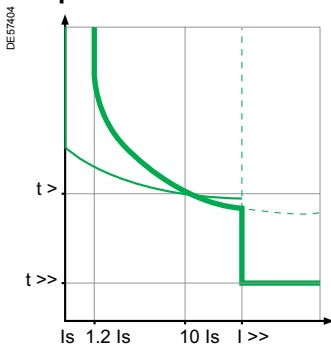

With a definite time lower threshold

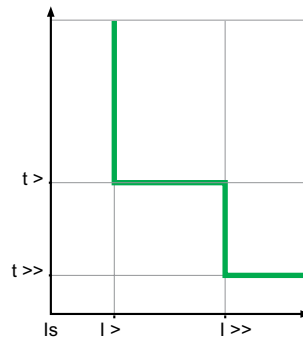

With an inverse definite time lower threshold

#### Definite time curves

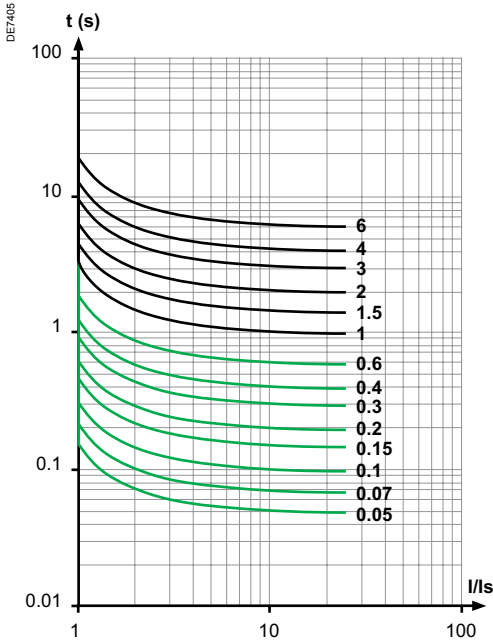

RI curve

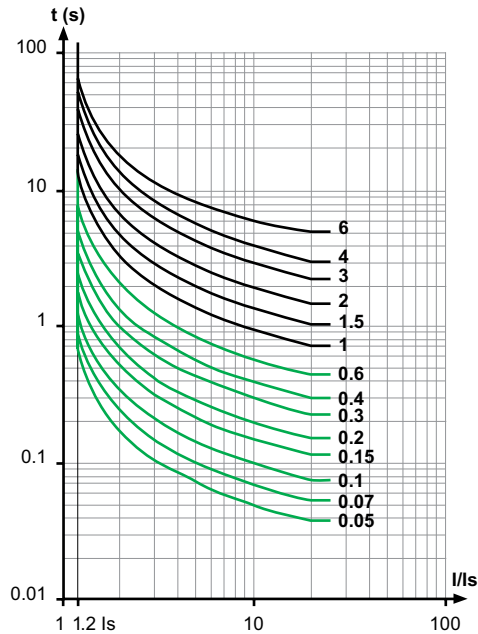

SI curve

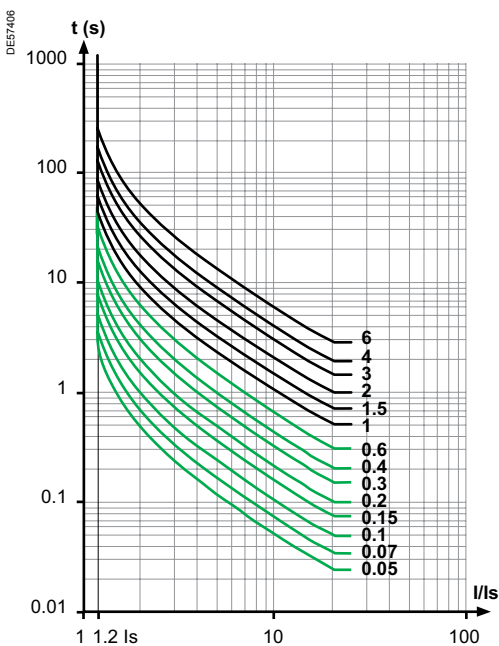

VI curve

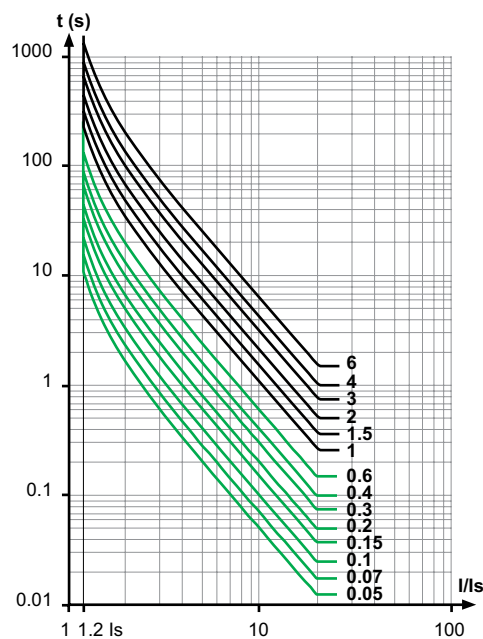

EI curve

# Protection, monitoring and control

## Current sensors and test unit for VIP300

PE55773



Cs type current sensors

### CSa and CSb current sensors for the VIP300

In order to achieve the specified performance levels, the VIP300 protection unit must be used with the specified sensors. The combination of the unit/sensor is essential in order to comply with characteristics and in particular with:

- operation throughout the whole range
- response time
- accuracy
- short circuit thermal withstand.

Two interchangeable sensors, **CSa** and **CSb**, suffice to cover all requirements from 10 A to 1250 A.

Sensor selection	Service current (Is)
CSa	10 A to 200 A
CSb	63 A to 1250 A

PE56614



VAP6 test unit

### VAP6 test unit

VIP type protection units have a “**test**”, socket to connect a VAP6 test unit. This portable unit with its own power supply enables the correct functioning of the protection unit to be checked.

## Basic fixed unit

### Operating mechanism on the right hand side (A1)

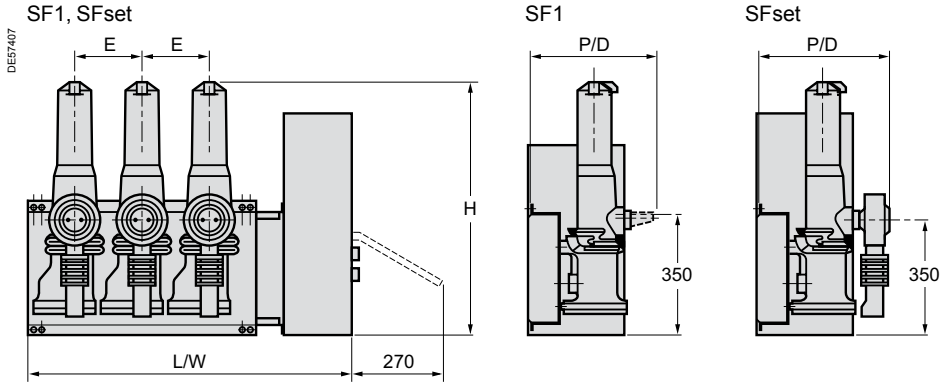

### Operating mechanism on the left hand side (B1)

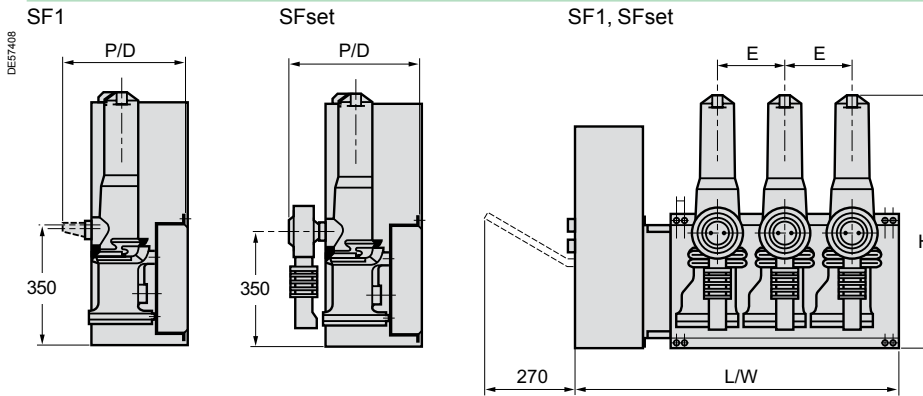

### Operating mechanism on the front (C1)

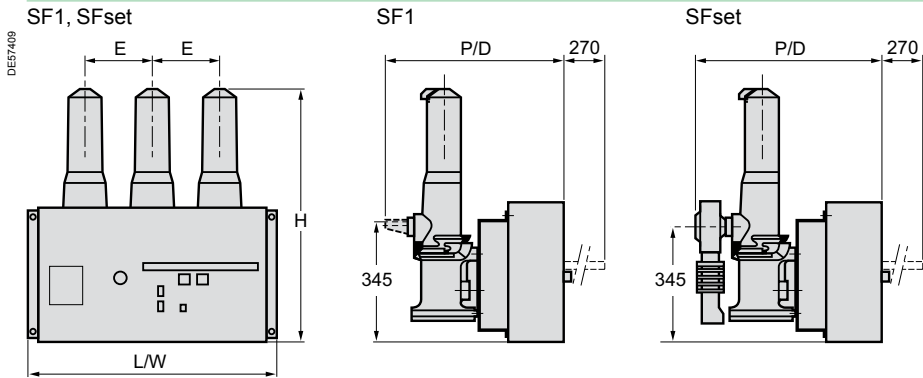

## Dimensions and weights

Rated voltage (kV)	SF1				Weight (kg)	SFset				Weight (kg)
	Dimensions (mm)					Dimensions (mm)				
	H	W	D	E		H	W	D	E	
<b>Operating mechanism on the right or left</b>										
17.5	750	993	290	220	78	750	993	420	220	88
24	750	1143	290	280	80	750	1143	420	280	90
36	750	1560	365	380	88					
<b>Operating mechanism on the front</b>										
17.5	745	766	490	220	78	745	766	620	220	88
24	745	886	490	280	80	745	886	620	280	90
36	745	927	559	350	85					
36	745	1260	565	380	88					

For SF circuit breakers with SM6, consult us.

## Fixed unit with support frame

### Operating mechanism on the right hand side (A1)

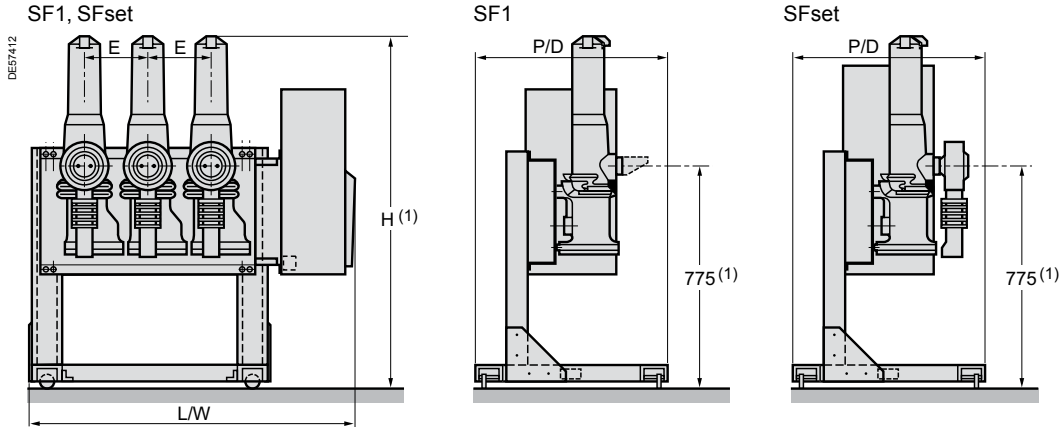

### Operating mechanism on the left hand side (B1)

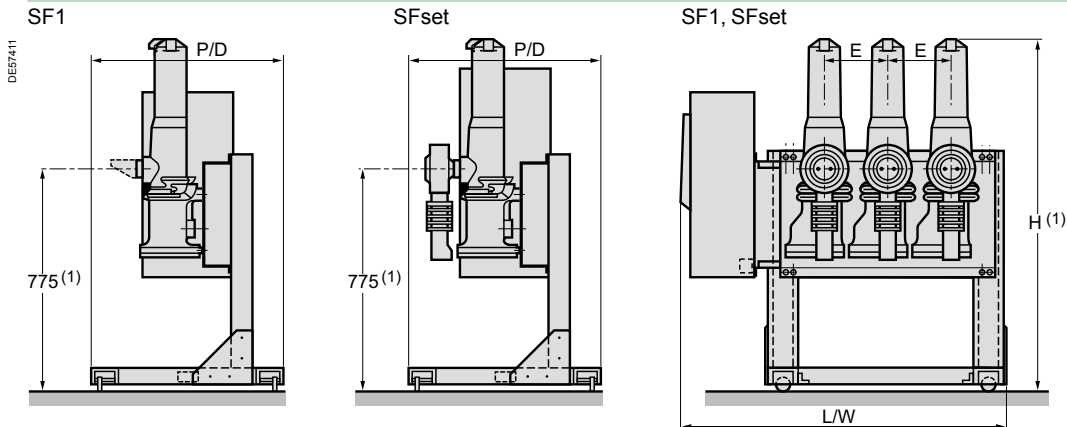

### Operating mechanism on the front (C1)

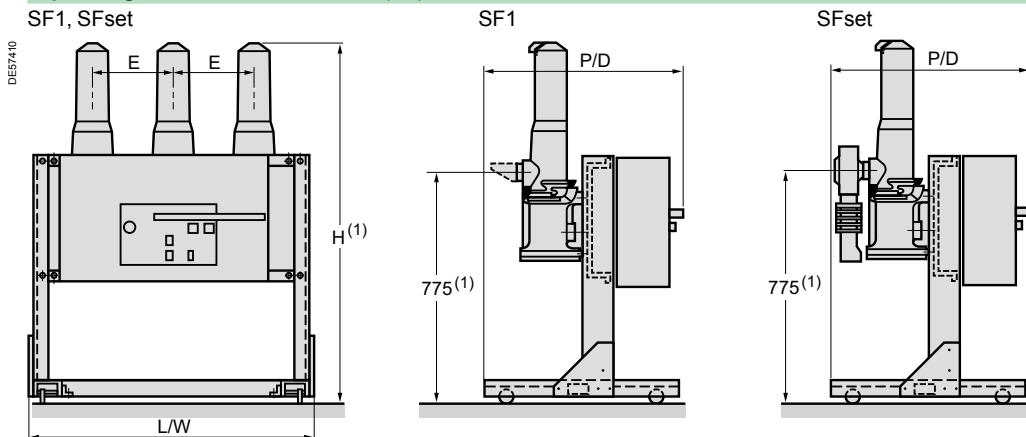

## Dimensions and weights

Rated voltage (kV)	SF1					SFset				
	Dimensions (mm)				Weight (kg)	Dimensions (mm)				Weight (kg)
	H	W	D	E		H	W	D	E	
<b>Operating mechanism on the right or left hand side</b>										
17.5	1175	1065	600	220	103	1175	1065	600	220	103
24	1175	1215	600	280	105	1175	1215	600	280	105
36	1175	632	600	380	113					
<b>Operating mechanism on the front</b>										
17.5	1175	853	600	220	103	1175	853	649	220	103
24	1175	973	600	280	105	1175	973	649	280	105
36	1175	1347	600	380	113					

(1) Additional holes, provided on the fixed support frame allow the device to be positioned 215 mm lower.

## Connection

### Top

$I_r \leq 630 \text{ A}$

SF1, SFset (A)

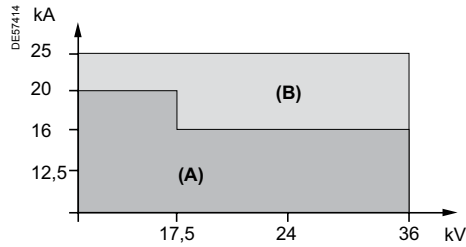
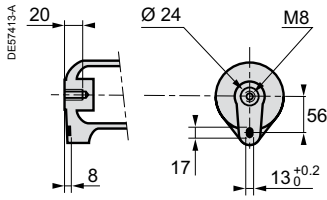

SF1, SFset (B)

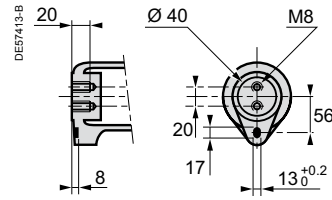

$I_r = 1250 \text{ A}$

SF1, SFset (B)

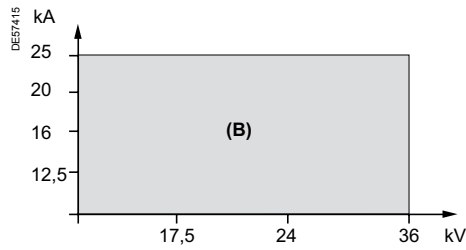
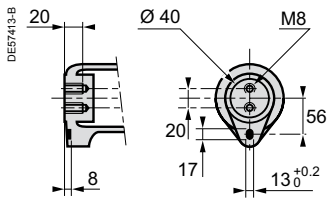

### Bottom

SF1, insulation  $\leq 125 \text{ kV}$  impulse

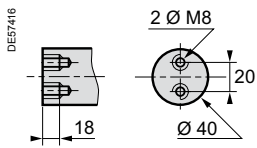

SF1, insulation  $\leq 170 \text{ kV}$  impulse

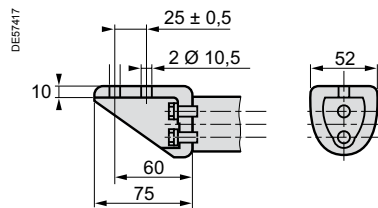

SFset

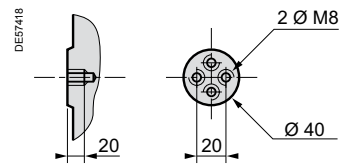

**Note:** recommended connection screw M8 class 8.8.  
Tightening torque: 28 Nm with contact washer.

Only one of the boxes (ticked  or filled ) by the needed value) have to be considered between each horizontal line.  
Green box  corresponds to none priced functions.

<b>Basic fixed circuit breaker</b>		Quantity	<input type="text"/>
Rated voltage $U_r$	(kV)	<input type="text"/>	
Impulse voltage $U_p$	(kVbil)	<input type="text"/>	
Short-circuit current $I_{sc}$	(kA)	<input type="text"/>	
Rated current $I_r$	(A)	<input type="text"/>	
Frequency	50 Hz <input checked="" type="checkbox"/>	60 Hz	<input checked="" type="checkbox"/>
Operating mechanism position	A1 <input checked="" type="checkbox"/>	B1 <input checked="" type="checkbox"/>	C1 <input checked="" type="checkbox"/>
<b>Colour for push buttons and indicators</b>			
Push buttons open/close:			Red/black <input checked="" type="checkbox"/>
Indicator open/close:			Black/white <input checked="" type="checkbox"/>
Operating mechanism charged/discharged:			White/yellow <input checked="" type="checkbox"/>

### Circuit breaker options

**1st opening release** (see possible choices in combination table below)

<b>Shunt opening release YO1</b>			
24 Vdc <input checked="" type="checkbox"/>	60 Vdc <input checked="" type="checkbox"/>	220 Vdc <input checked="" type="checkbox"/>	220 Vac (50 Hz) <input checked="" type="checkbox"/>
30 Vdc <input checked="" type="checkbox"/>	110 Vdc <input checked="" type="checkbox"/>	48 Vac (50 Hz) <input checked="" type="checkbox"/>	120 Vac (60 Hz) <input checked="" type="checkbox"/>
48 Vdc <input checked="" type="checkbox"/>	125 Vdc <input checked="" type="checkbox"/>	110 Vac (50 Hz) <input checked="" type="checkbox"/>	240 Vac (60 Hz) <input checked="" type="checkbox"/>
<b>Undervoltage release YM</b>			
24 Vdc <input type="checkbox"/>	60 Vdc <input type="checkbox"/>	220 Vdc <input type="checkbox"/>	220 Vac (50 Hz) <input type="checkbox"/>
30 Vdc <input type="checkbox"/>	110 Vdc <input type="checkbox"/>	48 Vac (50 Hz) <input type="checkbox"/>	120 Vac (60 Hz) <input type="checkbox"/>
48 Vdc <input type="checkbox"/>	125 Vdc <input type="checkbox"/>	110 Vac (50 Hz) <input type="checkbox"/>	240 Vac (60 Hz) <input type="checkbox"/>
Mitop	Without contact <input type="checkbox"/>		With contact <input type="checkbox"/>

**2nd opening release** (see possible choices in combination table below)

<b>Shunt opening release YO2</b>			
24 Vdc <input type="checkbox"/>	60 Vdc <input type="checkbox"/>	220 Vdc <input type="checkbox"/>	220 Vac (50 Hz) <input type="checkbox"/>
30 Vdc <input type="checkbox"/>	110 Vdc <input type="checkbox"/>	48 Vac (50 Hz) <input type="checkbox"/>	120 Vac (60 Hz) <input type="checkbox"/>
48 Vdc <input type="checkbox"/>	125 Vdc <input type="checkbox"/>	110 Vac (50 Hz) <input type="checkbox"/>	240 Vac (60 Hz) <input type="checkbox"/>
<b>Undervoltage release YM</b>			
24 Vdc <input type="checkbox"/>	60 Vdc <input type="checkbox"/>	220 Vdc <input type="checkbox"/>	220 Vac (50 Hz) <input type="checkbox"/>
30 Vdc <input type="checkbox"/>	110 Vdc <input type="checkbox"/>	48 Vac (50 Hz) <input type="checkbox"/>	120 Vac (60 Hz) <input type="checkbox"/>
48 Vdc <input type="checkbox"/>	125 Vdc <input type="checkbox"/>	110 Vac (50 Hz) <input type="checkbox"/>	240 Vac (60 Hz) <input type="checkbox"/>
Mitop	Without contact <input type="checkbox"/>		With contact <input type="checkbox"/>

### Remote control

Electrical motor M	24...32 Vdc <input type="checkbox"/>	110...127 Vdc/ac <input type="checkbox"/>
	48...60 Vdc/ac <input type="checkbox"/>	220...250 Vdc/ac <input type="checkbox"/>
<b>Shunt closing release YF</b>		
24 Vdc <input checked="" type="checkbox"/>	60 Vdc <input checked="" type="checkbox"/>	220 Vdc <input checked="" type="checkbox"/>
30 Vdc <input checked="" type="checkbox"/>	110 Vdc <input checked="" type="checkbox"/>	48 Vac (50 Hz) <input checked="" type="checkbox"/>
48 Vdc <input checked="" type="checkbox"/>	125 Vdc <input checked="" type="checkbox"/>	110 Vac (50 Hz) <input checked="" type="checkbox"/>
		220 Vac (50 Hz) <input checked="" type="checkbox"/>
		120 Vac (60 Hz) <input checked="" type="checkbox"/>
		240 Vac (60 Hz) <input checked="" type="checkbox"/>

<b>Low voltage wiring connection</b>	Male plug (1.2 m) <input type="checkbox"/>	Female socket (2 m) <input type="checkbox"/>
<b>Locking C.B. in open position</b>	Ronis <input type="checkbox"/>	Profalux <input type="checkbox"/>
<b>Support frame</b>	Low (560 mm) <input type="checkbox"/>	High (775 mm) <input type="checkbox"/>
<b>Leaflets language</b>	French <input checked="" type="checkbox"/>	English <input checked="" type="checkbox"/>
<b>Pressure switch</b> (not available for all electrical characteristics)		

Releases combinations table

Shunt opening releases YO1/YO2	1	1	2	1	1	1
Undervoltage release YM		1		1		1
Mitop			1		1	1

Only one of the boxes (ticked  or filled  by the needed value) have to be considered between each horizontal line.  
Green box  corresponds to none priced functions.

<b>Basic fixed circuit breaker</b>		Quantity	<input type="text"/>
Rated voltage $U_r$		(kV)	<input type="text"/>
Impulse voltage $U_p$		(kVbil)	<input type="text"/>
Short-circuit current $I_{sc}$		(kA)	<input type="text"/>
Rated current $I_r$		(A)	<input type="text"/>
Frequency	50 Hz <input checked="" type="checkbox"/>	60 Hz	<input checked="" type="checkbox"/>
Operating mechanism position	A1 <input checked="" type="checkbox"/>	B1 <input checked="" type="checkbox"/>	C1 <input checked="" type="checkbox"/>
<b>Colour for push buttons and indicators</b>			
Push buttons open/close:		Red/black	<input checked="" type="checkbox"/>
Indicator open/close:		Black/white	<input checked="" type="checkbox"/>
Operating mechanism charged/discharged:		White/yellow	<input checked="" type="checkbox"/>

<b>Control unit and sensors</b>			
VIP 300P (not available for all electrical characteristics)	CSa 200/1	$I_s = 10$ to 50 A <input type="checkbox"/>	$I_s = 40$ to 200 A <input type="checkbox"/>
	CSb 1250/1	$I_s = 63$ to 312 A <input type="checkbox"/>	$I_s = 250$ to 1250 A <input type="checkbox"/>
VIP 300LL	CSa 200/1	$I_s = 10$ to 50 A <input type="checkbox"/>	$I_s = 40$ to 200 A <input type="checkbox"/>
	CSb 1250/1	$I_s = 63$ to 312 A <input type="checkbox"/>	$I_s = 250$ to 1250 A <input type="checkbox"/>

<b>Circuit breaker options</b>			
<b>2nd opening release</b> (see possible choices in combination table below)			
Shunt opening release <b>YO2</b>			
24 Vdc <input type="checkbox"/>	60 Vdc <input type="checkbox"/>	220 Vdc <input type="checkbox"/>	220 Vac (50 Hz) <input type="checkbox"/>
30 Vdc <input type="checkbox"/>	110 Vdc <input type="checkbox"/>	48 Vac (50 Hz) <input type="checkbox"/>	120 Vac (60 Hz) <input type="checkbox"/>
48 Vdc <input type="checkbox"/>	125 Vdc <input type="checkbox"/>	110 Vac (50 Hz) <input type="checkbox"/>	240 Vac (60 Hz) <input type="checkbox"/>
Undervoltage release <b>YM</b>			
24 Vdc <input type="checkbox"/>	60 Vdc <input type="checkbox"/>	220 Vdc <input type="checkbox"/>	220 Vac (50 Hz) <input type="checkbox"/>
30 Vdc <input type="checkbox"/>	110 Vdc <input type="checkbox"/>	48 Vac (50 Hz) <input type="checkbox"/>	120 Vac (60 Hz) <input type="checkbox"/>
48 Vdc <input type="checkbox"/>	125 Vdc <input type="checkbox"/>	110 Vac (50 Hz) <input type="checkbox"/>	240 Vac (60 Hz) <input type="checkbox"/>

<b>Remote control</b>			
Electrical motor <b>M</b>	24...32 Vdc <input type="checkbox"/>	110...127 Vdc/ac <input type="checkbox"/>	
	48...60 Vdc/ac <input type="checkbox"/>	220...250 Vdc/ac <input type="checkbox"/>	
Shunt closing release <b>YF</b>			
24 Vdc <input checked="" type="checkbox"/>	60 Vdc <input checked="" type="checkbox"/>	220 Vdc <input checked="" type="checkbox"/>	220 Vac (50 Hz) <input checked="" type="checkbox"/>
30 Vdc <input checked="" type="checkbox"/>	110 Vdc <input checked="" type="checkbox"/>	48 Vac (50 Hz) <input checked="" type="checkbox"/>	120 Vac (60 Hz) <input checked="" type="checkbox"/>
48 Vdc <input checked="" type="checkbox"/>	125 Vdc <input checked="" type="checkbox"/>	110 Vac (50 Hz) <input checked="" type="checkbox"/>	240 Vac (60 Hz) <input checked="" type="checkbox"/>

Low voltage wiring connection	Male plug (1.2 m) <input type="checkbox"/>	Female socket (2 m) <input type="checkbox"/>
Locking C.B. in open position	Ronis <input type="checkbox"/>	Profalux <input type="checkbox"/>
Support frame	Low (560 mm) <input type="checkbox"/>	High (775 mm) <input type="checkbox"/>
Test unit (VAP 6)	<input type="checkbox"/>	
Leaflets language	French <input checked="" type="checkbox"/>	English <input checked="" type="checkbox"/>
Pressure switch (not available for all electrical characteristics)	<input type="checkbox"/>	

Releases combinations table

Mitop	1	1	1
Shunt opening release <b>YO2</b>		1	
Undervoltage release <b>YM</b>			1



---

<b>Presentation</b>	<b>26</b>
<b>General characteristics</b>	<b>27</b>
<b>Description of functions</b>	<b>28</b>
GMH stored energy operating mechanism	28
Wiring diagram	28
Opening circuit	29
Remote control	30
Indication and locking/interlocking	31
<b>Dimensions</b>	<b>32</b>
<b>Order form</b>	<b>33</b>

PEE6501



## Description of the device

### The basic fixed version of the SF circuit breaker comprises:

- 3 main independent poles, that are mechanically linked and each comprising a “sealed pressure system” type insulating enclosure. The sealed enclosure is filled with low pressure SF6 gas
  - a GMH stored energy electrical operating mechanism.
- This gives the device an opening and closing speed that is independent of the operator, for both electrical and manual orders.
- The circuit breaker can be remotely controlled and it is possible to carry out reclosing cycles.
- a front panel housing the manual operating mechanism and status indicators
  - upstream and downstream terminals for the power circuit connection
  - a terminal block for connection of external auxiliary circuits.
- The SF circuit breaker is only available with a frontal operating mechanism.

### Each device can be optionally equipped with:

- a support frame fitted with rollers and floor securing brackets for a fixed installation
- locking of the circuit breaker in the open position by a keylock installed on the control panel
- a pressure switch for the high performance versions
- a Harting 42-pin type LV connector.

## Applications

SF circuit breakers are 3-pole MV circuit breakers for indoor installation. They are mainly used for switching and protection of networks from 24 to 40.5 kV in primary and secondary power distribution.

The autocompression breaking technique used in these circuit breakers means that making or breaking all types of capacitive or inductive currents can be achieved without dangerous overvoltages for the switchgear connected to the network.

The SF circuit breaker is therefore well suited to operating capacitor banks.

Electrical characteristics according to IEC 62271-100				SF2							
Rated voltage	<b>Ur</b>	kV 50/60 Hz		24				36		40.5	
Insulation voltage											
- power frequency withstand	<b>Ud</b>	kV 50 Hz 1min		50				70		85	
- lightning impulse withstand	<b>Up</b>	kV peak		125				170		185	
Rated current	<b>Ir</b>	A	630	-	-	■	■	-	■	■	-
			1250	-	-	■	■	-	■	■	-
			2500	■	■	■	■	■	■	■	■
			3150	-	-	-	■	-	-	■	-
Short circuit current	<b>Isc</b>	kA		12.5	25	31.5	40	25	31.5	40	31.5
Short time withstand current	<b>Ik/tk</b>	kA/3 s		12.5	25	31.5	40	25	31.5	40	31.5
Short-circuit making current	<b>Ip</b>	kA peak	50 Hz	31.3	63	79	100	62.5	79	100	78.8
			60 Hz	32.5	65	82	104	65	82	104	81.9
Rated switching sequence		O-3 min-CO-3 min-CO		■	■	■	■	■	■	■	■
		O-0.3 s-CO-3 min-CO		■	■	■	-	■	■	-	■
		O-0.3 s-CO-15 s-CO		■	■	■	-	■	■	-	-
Phase to phase		mm	300	■	■	■	■	-	-	-	-
			400	-	-	-	-	■	■	■	-
			457	-	-	-	-	-	-	-	■
Operating mechanism		Frontal		■				■		■	
Operating times		Opening (ms)		< 50							
		Breaking (ms)		< 60							
		Closing (ms)		< 65							
Service temperature	<b>T</b>	°C		-25 to +40							
Mechanical endurance		Class		M2							
		Number of switching operations		10,000							
Electrical endurance		Class		E2							
Capacitive current breaking capacity		Class		C2							

■ Available  
- Not available.

## Specific applications

### Switching and protection of capacitor banks

SF range circuit breakers are particularly well suited to switching and protection of capacitor banks; they are classed C2 according to standard IEC 62271-100. Tests carried out according to the standard for breaking at 400 A with making and breaking cycles in case of a capacitor bank with a making current of 20 kA. Additional tests have been carried out: please consult us.

# Description of functions

## GMH stored energy operating mechanism

### Wiring diagram

0230388



#### Operation of the electrical GMH stored energy mechanism

This gives the device an opening and closing speed that is independent of the operator whether the order is electrical or manual.

The electrical control mechanism carries out reclosing cycles and is automatically recharged by a geared motor each time after closing.

#### It consists of:

- the stored energy operating mechanism which stores in springs the energy required to open and close the device
- a manual lever arming device for the springs
- an electrical arming device with a motor to automatically rearm the control mechanism as soon as the circuit breaker is closed (optional)
- manual push-button controls on the front face of the circuit breaker (red and black)
- an electrical remote-closing device comprising a release and an anti-pumping relay.
- an electrical opening device comprising one or several releases of the following type:
  - shunt opening
  - undervoltage
  - Mitop, low energy release.
- an operation counter
- an open/closed position indicator with a mechanical indicator (black and white)
- an "armed" control mechanism status indicator with a mechanical indicator and an electrical contact (optional)
- a block of 14 auxiliary contacts, available according to the wiring layout used
- a pressure switch contact activated by a drop in gas pressure (optional: single or double threshold pressure switch).

#### Wiring diagram (principle)

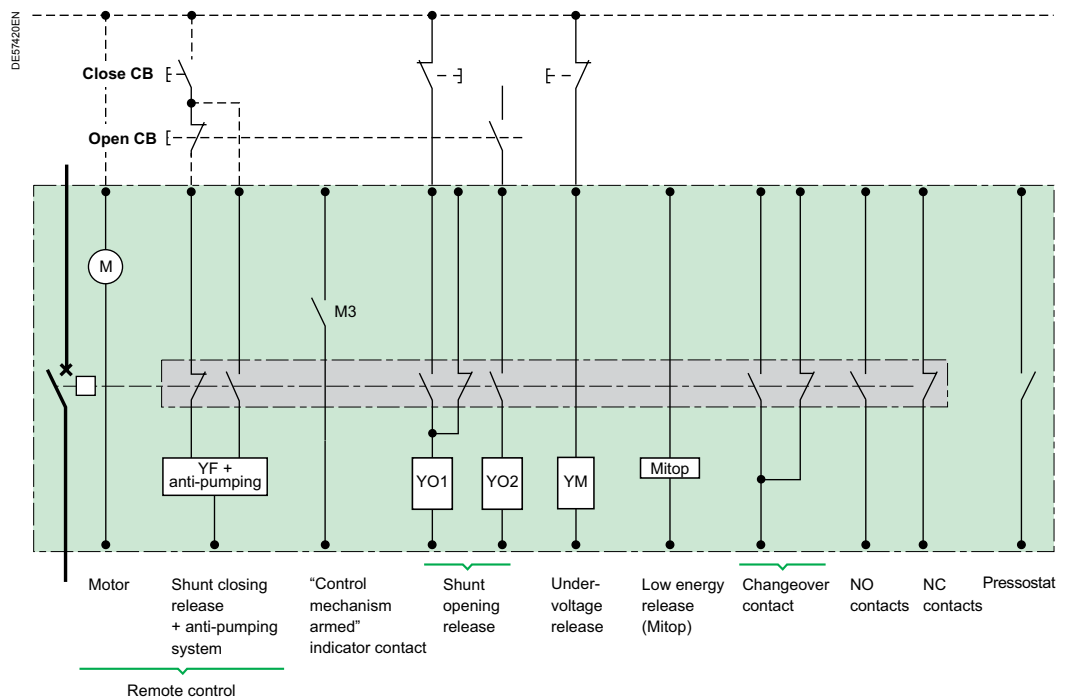

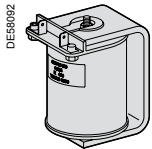
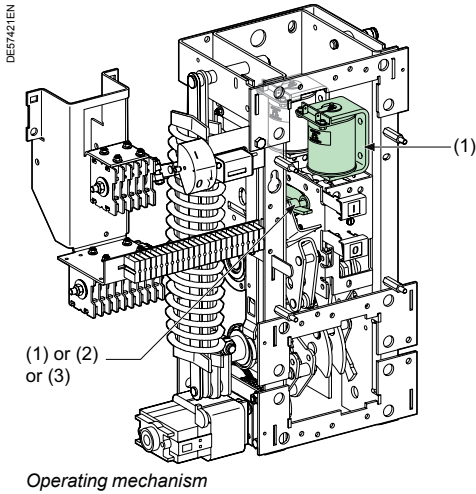

Shunt opening release (1)

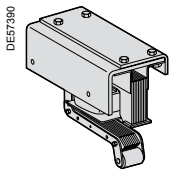

Undervoltage release (2)

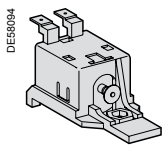

Low energy release (3)

### Composition

The opening circuit can be produced using the following components:

- a shunt opening release (on energizing) (YO1)
- a second shunt opening release (on energizing) (YO2)
- undervoltage release (YM)
- low energy release (Mitop).

**Note:** see the table of the releases' combinations page "Order form".

### Shunt opening release (YO1 and YO2)

Energizing this unit causes instant opening of the circuit breaker.

#### Characteristics

Power supply	See "Order form" page	
Threshold	V AC	0.85 to 1.1 Ur
	V DC	0.7 to 1.1 Ur
Consumption	V AC	160 VA
	V DC	50 W

### Undervoltage release (YM)

This release unit causes the systematic opening of the circuit breaker when its supply voltage drops below a value less than 35% of the rated voltage, even if this drop is slow and gradual. It can open the circuit breaker between 35% and 70% of its rated voltage. If the release unit is not supplied power, manual or electrical closing of the circuit breaker is impossible. Closing of the circuit breaker is compulsory when the supply voltage of the release unit reaches 85% of its rated voltage.

#### Characteristics

Power supply	See "Order form" page		
Threshold	Opening	0.35 to 0.7 Ur	
	Closing	0.85 Ur	
Consumption	Triggering	V AC	400 VA
		V DC	100 W
	Latched	V AC	100 VA
		V DC	10 W

### Low energy release (Mitop)

This specific release unit comprises a low consumption unit.

#### Characteristics

Power supply	Direct current
Threshold	0.04 A < I < 0.12 A

Any tripping due to the Mitop release unit is momentarily indicated by an SDE type changeover contact (option).

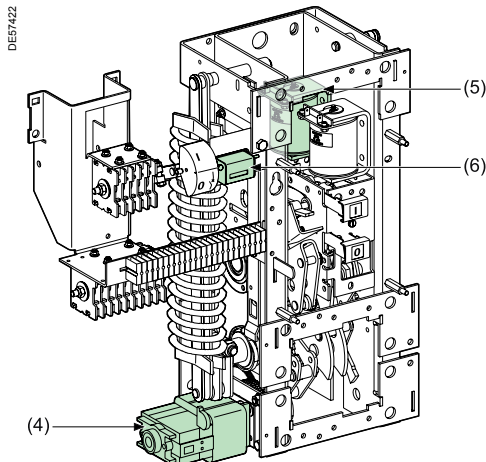

Operating mechanism

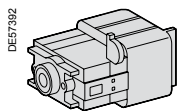

Electrical motor (4)

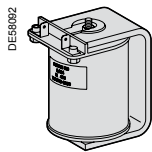

Shunt closing release (5)

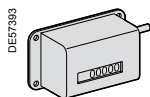

Operation counter (6)

### Function

Remote control enables the remote opening and closing of the circuit breaker.

### Composition

The remote control mechanism comprises:

- an electrical motor with gearing
- a shunt closing release (YF) combined with an anti-pumping device
- an operation counter.

### Electrical motor (M)

The electrical motor carries out the automatic rearming of the stored energy unit as soon as the circuit breaker is closed. This allows the instant reclosing of the device after opening. The arming lever is only used as a backup operating mechanism in the case of the absence of the auxiliary power supply. The M3 contact indicates the end of arming operations.

#### Characteristics

Power supply	See "Order form" page	
Threshold	V AC/V DC	0.85 to 1.1 Ur
Consumption	V AC	380 VA
	V DC	380 W

### Shunt closing release (YF)

This release allows the remote closing of the circuit breaker when the operating mechanism is armed.

#### Characteristics

Power supply	See "Order form" page	
Threshold	V AC	0.85 to 1.1 Ur
	V DC	0.85 to 1.1 Ur
Consumption	V AC	160 VA
	V DC	50 W

The shunt closing release is combined with an anti-pumping relay that enables priority to be given to opening in the case of a permanent closing order. This thus avoids the device being caught in an uncontrolled opening-closing cycle.

### Operation counter

The operation counter is visible on the front panel.

It displays the number of switching cycles (CO) that the device has carried out.

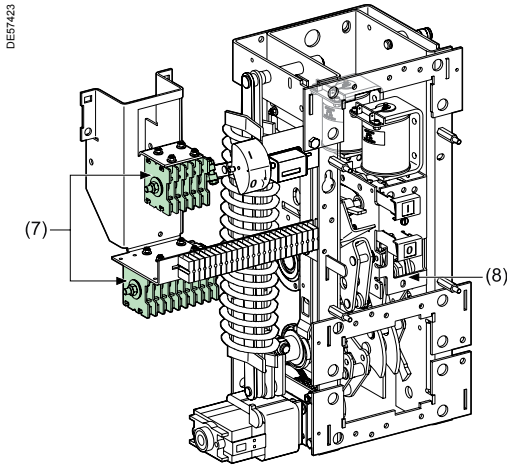

Operating mechanism

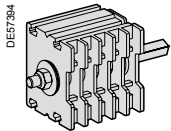

Auxiliary contacts (7)

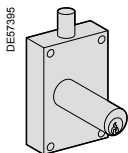

Keylocking kit (8)

### “Open/closed” auxiliary contacts

The number of contacts available depends on the options chosen on the operating mechanism.

In the basic configuration, the circuit breaker’s operating mechanism comprises a total of:

- 6 normally closed contacts (NC)
- 7 normally open contacts (NO)
- 1 changeover contact (CHG).

The usage procedure for auxiliary contacts is given in the following table:

Options	NC contact	NO contact
Remote control	1	1
Shunt opening release (each one) YO1/YO2	0	1
Undervoltage release YM	0	0
Low energy release (Mitop)	0	0

In order to know the final number of available contacts, you must deduct the total number of contacts included in the circuit breaker (6 NC + 7 NO + 1 CHG), the number of contacts used given in the table above.

**E.g.:** a circuit breaker equipped with a remote control and a shunt trip unit has the following available contacts:

6 NC + 5 NO + 1 CHG.

With a undervoltage release instead of the shunt trip, this circuit breaker would have the following available contacts:

6 NC + 6 NO + 1 CHG.

Shunt opening release combination				
	1st release	Shunt opening release YO1	Undervoltage release YM	Mitop
2nd release				
Without		6NC + 5NO + 1CHG	6NC + 6NO + 1CHG	6NC + 6NO + 1CHG
Shunt opening release YO2		6NC + 4NO + 1CHG		
Undervoltage release YM		6NC + 5NO + 1CHG		
Mitop		6NC + 5NO + 1CHG	6NC + 6NO + 1CHG	

### Locking the circuit breaker in the “open” position

This key-operated device allows the circuit breaker to be locked in the “open” position. The circuit breaker is locked in the open position by blocking the opening push button in the “engaged” position.

Locking is achieved using a Profalux or Ronis captive key type keylock.

## Basic fixed unit

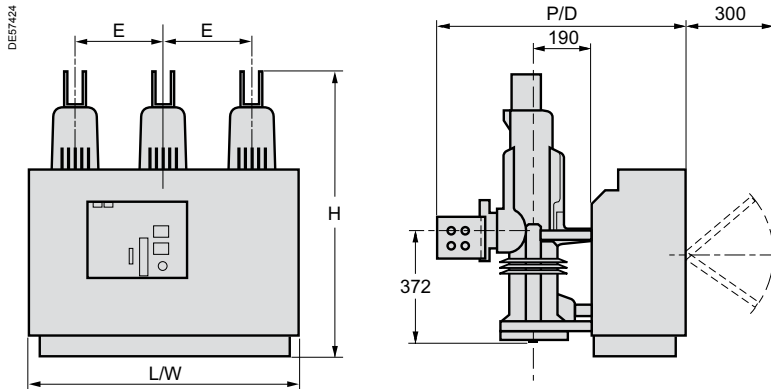

## Fixed unit with a support frame

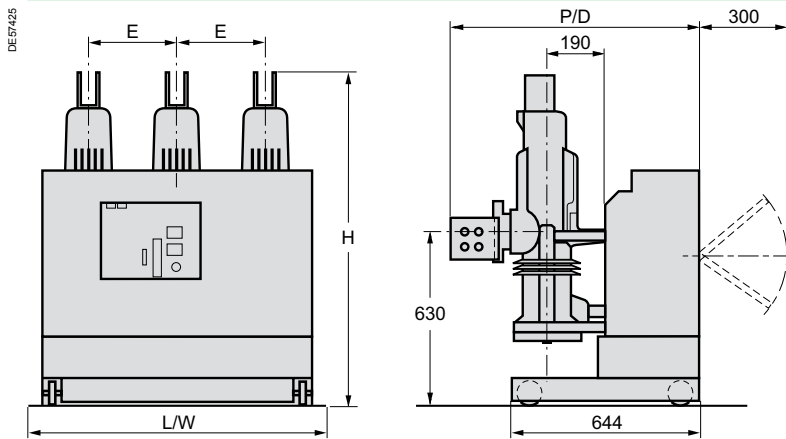

## Connection

630, 1250 A (24-36 kV)

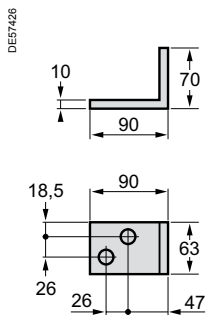

2500, 3150 A (24-36 kV)

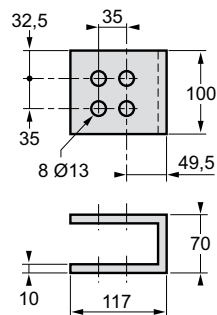

2000, 2500 A (40.5 kV)

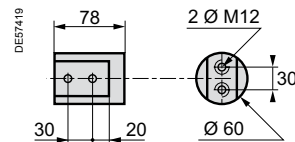

## Dimensions and weights

Rated current (A)	Rated voltage (kV)	Basic fixed unit				Weight (kg)	Fixed unit with support frame				Weight (kg)
		Dimensions (mm)					Dimensions (mm)				
		H	L	P	E		H	L	P	E	
630, 1250	24	825	910	750	300	159	1030	910	750	300	179
	36	825	1110	750	400	212	1030	1110	750	400	239
	40.5	825	1224	750	457	242	1030	1224	750	457	272
2500, 3150	24	942	910	777	300	174	1147	910	777	300	194
	36	942	1110	777	400	227	1147	1110	777	400	254
	40.5	942	1224	777	457	242	1147	1224	777	457	272

Only one of the boxes (ticked  or filled  by the needed value) have to be considered between each horizontal line.  
Green box  corresponds to none priced functions.

<b>Basic fixed circuit breaker</b>		Quantity	<input type="text"/>
Rated voltage $U_r$		(kV)	<input type="text"/>
Impulse voltage $U_p$		(kVbil)	<input type="text"/>
Short-circuit current $I_{sc}$		(kA)	<input type="text"/>
Rated current $I_r$		(A)	<input type="text"/>
Frequency	50 Hz <input checked="" type="checkbox"/>	60 Hz	<input type="checkbox"/>
<b>Colour for push buttons and indicators</b>			
Push buttons open/close:		Red/black	<input checked="" type="checkbox"/>
Indicator open/close:		Black/white	<input checked="" type="checkbox"/>
Operating mechanism charged/discharged:		White/yellow	<input checked="" type="checkbox"/>

### Circuit breaker options

**1st opening release** (see possible choices in combination table below)

Shunt opening release **YO1**

24 Vdc <input checked="" type="checkbox"/>	60 Vdc <input checked="" type="checkbox"/>	220 Vdc <input checked="" type="checkbox"/>	250 Vac (50 Hz) <input checked="" type="checkbox"/>
32 Vdc <input checked="" type="checkbox"/>	100-109 Vdc <input checked="" type="checkbox"/>	110 Vac (50 Hz) <input checked="" type="checkbox"/>	120 Vac (60 Hz) <input checked="" type="checkbox"/>
48 Vdc <input checked="" type="checkbox"/>	100-127 Vdc <input checked="" type="checkbox"/>	220 Vac (50 Hz) <input checked="" type="checkbox"/>	240 Vac (60 Hz) <input checked="" type="checkbox"/>

Undervoltage release **YM**

24 Vdc <input type="checkbox"/>	60 Vdc <input type="checkbox"/>	220 Vdc <input type="checkbox"/>	220 Vac (50 Hz) <input type="checkbox"/>
32 Vdc <input type="checkbox"/>	110 Vdc <input type="checkbox"/>	48 Vac (50 Hz) <input type="checkbox"/>	120 Vac (60 Hz) <input type="checkbox"/>
48 Vdc <input type="checkbox"/>	125 Vdc <input type="checkbox"/>	110 Vac (50 Hz) <input type="checkbox"/>	240 Vac (60 Hz) <input type="checkbox"/>

Mitop	Without contact <input type="checkbox"/>	With contact <input type="checkbox"/>
-------	--	---------------------------------------

**2nd opening release** (see possible choices in combination table below)

Shunt opening release **YO2**

24 Vdc <input type="checkbox"/>	60 Vdc <input type="checkbox"/>	220 Vdc <input type="checkbox"/>	250 Vac (50 Hz) <input type="checkbox"/>
32 Vdc <input type="checkbox"/>	100-109 Vdc <input type="checkbox"/>	110 Vac (50 Hz) <input type="checkbox"/>	120 Vac (60 Hz) <input type="checkbox"/>
48 Vdc <input type="checkbox"/>	100-127 Vdc <input type="checkbox"/>	220 Vac (50 Hz) <input type="checkbox"/>	240 Vac (60 Hz) <input type="checkbox"/>

Undervoltage release **YM**

24 Vdc <input type="checkbox"/>	60 Vdc <input type="checkbox"/>	220 Vdc <input type="checkbox"/>	220 Vac (50 Hz) <input type="checkbox"/>
32 Vdc <input type="checkbox"/>	110 Vdc <input type="checkbox"/>	48 Vac (50 Hz) <input type="checkbox"/>	120 Vac (60 Hz) <input type="checkbox"/>
48 Vdc <input type="checkbox"/>	125 Vdc <input type="checkbox"/>	110 Vac (50 Hz) <input type="checkbox"/>	240 Vac (60 Hz) <input type="checkbox"/>

Mitop	Without contact <input type="checkbox"/>	With contact <input type="checkbox"/>
-------	--	---------------------------------------

### Remote control

Electrical motor <b>M</b>	24...32 Vdc <input checked="" type="checkbox"/>	110...127 Vdc/ac <input type="checkbox"/>
	48...60 Vdc/ac <input type="checkbox"/>	220...250 Vdc/ac <input type="checkbox"/>

Shunt closing release **YF**

24 Vdc <input checked="" type="checkbox"/>	60 Vdc <input checked="" type="checkbox"/>	220 Vdc <input checked="" type="checkbox"/>	220 Vac (50 Hz) <input checked="" type="checkbox"/>
32 Vdc <input checked="" type="checkbox"/>	110 Vdc <input checked="" type="checkbox"/>	48 Vac (50 Hz) <input checked="" type="checkbox"/>	120 Vac (60 Hz) <input checked="" type="checkbox"/>
48 Vdc <input checked="" type="checkbox"/>	125 Vdc <input checked="" type="checkbox"/>	110 Vac (50 Hz) <input checked="" type="checkbox"/>	240 Vac (60 Hz) <input checked="" type="checkbox"/>

<b>Low voltage wiring connection</b>	Male plug (1.2 m) <input type="checkbox"/>	Female socket (2 m) <input type="checkbox"/>
<b>Locking C.B. in open position</b>	Ronis <input type="checkbox"/>	Profalux <input type="checkbox"/>
<b>Pressure switch</b>		
<b>Support frame</b>		
<b>Leaflets language</b>	French <input checked="" type="checkbox"/>	English <input type="checkbox"/>

*Releases combinations table*

Shunt opening releases <b>YO1/YO2</b>	1	2	1	1
Undervoltage release <b>YM</b>	1		1	
Mitop		1		1



---

<b>Presentation</b>	<b>36</b>
<b>General characteristics</b>	<b>37</b>
<b>Description of functions</b>	<b>38</b>
Racking-in	38
MV and LV connection	40
GMH stored energy operating mechanism	41
Wiring diagram	41
Opening circuit	42
Remote control	43
Indication and locking/interlocking	44
Safety functions	45
<b>Dimensions</b>	<b>46</b>
<b>Order form</b>	<b>48</b>

PEE6502



## Device description

### The basic withdrawable version of the SF circuit breaker comprises:

- the circuit breaker unit with its control mechanism:
  - 3 main independent poles, that are mechanically linked and each comprising a “sealed pressure system” type insulating enclosure. The sealed enclosure is filled with low pressure SF6 gas
  - a GMH stored energy electrical operating mechanism
- This gives the device an closing and opening speed that is independent of the operator, whether the control order is electrical or manual. When remotely controlled, the circuit breaker allows reclosing cycles to be performed
- a front face with status indicators
- racking components:
  - the circuit breaker is equipped with racking arms and clusters. It is mounted on a racking/unracking unit with a threaded shaft actuated by a crank which includes all of the safety interlocking systems
  - a Harting type male LV connector for external auxiliary circuits. The SF circuit breaker is only available with front controls.

### Each device can be fitted with the following options:

- position locking of the circuit breaker:
  - open, by a keylock installed on the control panel
  - racked out, by a keylock installed on the racking device
- the M1 and M2 basic cassettes comprising:
  - a metal structure and one guide rail
  - fixed connector fingers insulated by bushings
  - metal insulating shutters for the MV part
  - safety interlocking systems
  - Harting type female LV connector
  - indicator contacts for circuit breaker racked-in or racked-out positions (4 NO + 4NC)
  - a circuit breaker control mechanism spring discharge system
  - a circuit breaker racking-in blocking mechanism
  - an equipped door
  - a foolproofing system for the circuit breaker rating.

## Applications

SF circuit breakers are 3-pole MV circuit breakers for indoor installation. They are mainly used for switching and protection of networks from 24 to 40.5 kV in primary and secondary power distribution.

The autocompression breaking technique used in these circuit breakers means that making or breaking all types of capacitive or inductive currents can be achieved without dangerous overvoltages for the switchgear connected to the network.

The SF circuit breaker is therefore well suited to operating capacitor banks.

Electrical characteristics according to IEC 62271-100				SF F400					
				24	36			40,5	
Rated voltage	<b>Ur</b>	kV 50/60 Hz							
Insulation voltage									
- power frequency withstand	<b>Ud</b>	kV 50 Hz 1min		50	70			85	85
- lightning impulse withstand	<b>Up</b>	kV peak		125	170			185	185
Rated current	<b>Ir</b>	A	1250	–	■	■	■	■	■
			2500	■**	–	■	■	–	–
Short circuit current	<b>Isc</b>	kA		40	25 *	31.5	40	25	31.5
Short time withstand current	<b>Ik/tk</b>	kA/3 s		40	25	31.5	40	25	31.5
Short-circuit making current	<b>Ip</b>	kA peak	50 Hz	100	62.5	79	100	62.5	79
			60 Hz	104	–	82	104	65	82
Rated switching sequence			O-3 min-CO-3 min-CO	■	■	■	■	■	■
			O-0.3 s-CO-3 min-CO	–	■	■	–	■	■
			O-0.3 s-CO-15 s-CO	–	■	–	–	–	–
Phase to phase		mm	300	■	■	■	■	■	■
Operating mechanism		Frontal		■	■	■	■	■	■
Operating times			Opening (ms)	< 50					
			Breaking (ms)	< 60					
			Closing (ms)	< 65					
Service temperature	<b>T</b>	°C		–25 to +40					
Mechanical endurance			Class	M2					
			Number of switching operations	10,000					
Electrical endurance			Class	E2					
Capacitive current breaking capacity			Class	C2					

■ Available  
 – Not available  
 (\*) Only 50 Hz possible  
 (\*\*) 3000 A possible (please consult us).

## Specific applications

### Switching and protection of capacitor banks

SF range circuit breakers are particularly well suited to switching and protection of capacitor banks; they are classed C2 according to standard IEC 62271-100. Tests carried out according to the standard for breaking at 400 A with making and breaking cycles in case of a capacitor bank with a making current of 20 kA. Additional tests have been carried out: please consult us.

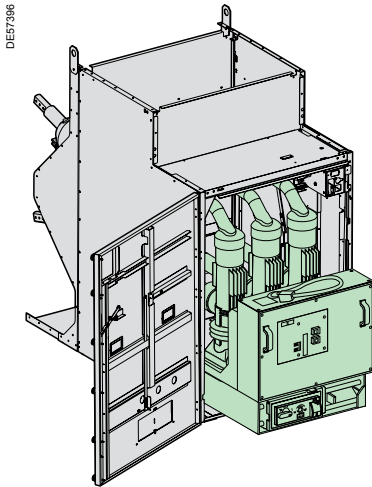

### Overall composition

The "racking-in/racking-out" function is achieved by:

- the SF F400 withdrawable circuit breaker with its LV connector (moving part)
- the M1 or M2 cassettes with their bushings (fixed part).

### Switching the circuit breaker

The withdrawable circuit breaker can be moved between three stable positions:

- **service position:** the circuit breaker racked-in and locked in position, the LV connector is connected
- **test position:** the circuit breaker is racked-out and locked in position, the LV connector is connected
- **disconnected position:** the circuit breaker is racked-out and locked in position, the LV connector is disconnected.

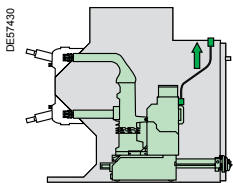

Service position

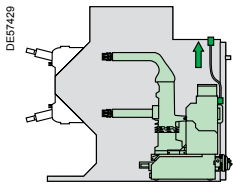

Test position

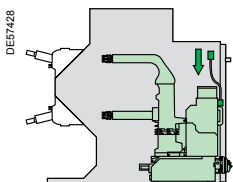

disconnected position

### SF F400 circuit breaker safety functions

A racking system with a threaded shaft makes it easier to rack-in and rack-out.

#### Test position contact

This is activated when the circuit breaker is in the "test" or "service" positions. Earthing is achieved throughout the operation through the racking carriage wheels.

#### Interlocking

In conformity with standards IEC 62271-100 and 62271-200, the following interlocks are available:

- prohibiting racking-in or racking-out if the circuit breaker is not in the open position
- prohibiting racking-in of the circuit breaker if the LV connector is not connected
- prohibiting disconnecting of the LV connector if the circuit breaker is not racked-out.

#### Interlocking with the cubicle door

The racking base is equipped with a device that allows interlocking between racking-out of the circuit breaker and the cubicle door.

- only possible to rack-in the circuit breaker if the door is closed
- only possible to open the door if the circuit breaker is racked-out.

This device must be disabled if this interlocking function is not present.

### M1 and M2 cassettes safety features

The M1 or M2 cassettes are fitted with the SF F400 circuit breaker and comprise the following safety features for racking-in.

#### A metal structure with one guide rail

The rail guides the circuit breaker during racking-in/racking-out operations.

#### Fixed connector fingers, insulated by bushings

The three ends of the circuit breaker, with their racking clusters, make the contact with these three fingers.

#### Metal insulating shutters for the MV part

Protective shutters mounted on the structure stop fingers from accessing the racking mechanism when the circuit breaker is extracted (protection index: IP2X).

#### Safety interlocking systems

When carrying out maintenance operations it is possible to:

- padlock the shutters in the locked position
- unlock the fixed contact access mechanism.

#### A control spring discharge system

The springs of the circuit breaker mechanism are automatically discharged when it is extracted from the cassette. This function avoids any risk of nuisance closing of the circuit breaker.

#### Foolproofing system

This allows the circuit breaker rating to be matched to the cassette rating. This system is mounted on the cassette side. The panel builder must ensure that the right circuit breaker rating is being used.

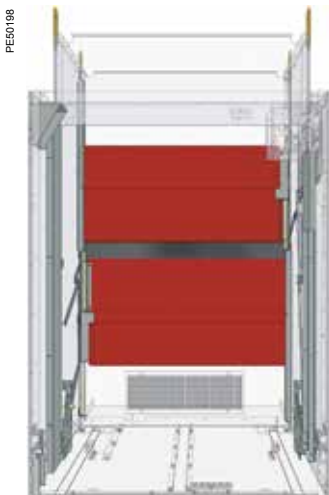

Protective shutters

PE60201



### Locking/interlocking functions

#### Possibilities for padlocking

For further operator safety it is possible to use a padlock:

- on the connector to lock the selector
- on the shutter protecting the mechanical opening pushbutton
- on the shutter opening mechanism in the circuit breaker compartment
- on the rotary voltage transformer switching mechanism.

PE60202



#### A mechanism to prohibit racking-in of the moving part

A mechanism associated with a padlock or a keylock prohibits the racking-in of the moving part. Locking is either achieved via:

- 1 to 3 padlocks, not supplied
- 1 keylock (optional).

PE60204

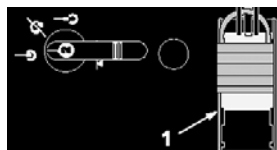

#### A blocking system for the circuit breaker opening order, when it is closed

This device can also be used as an additional way of prohibiting racking-in and out.

A transparent shutter blocks access to the opening and closing pushbutton.

The device allows independent locking of the opening or closing button.

It is often associated with an electrical motor (M). Locking is achieved by a padlock (not supplied) mounted on the shutter protecting the mechanical opening pushbutton.

PE60205



#### A system to prohibit disconnection of the moving part

This keylocking system prohibits disconnection of the moving part. It may be used for a circuit breaker or for a racking base.

### Optional accessories

- a self-adhesive front plate shows circuit breaker racking-in and racking-out operations. It is systematically delivered when the circuit breaker is ordered with the cassette or can be ordered separately.
- 4 "racked-in/racked-out" position contacts.
- 1 position contact for the cassette locked in the "racked-in/racked-out" position.
- a keylocking system (Ronis or Profalux) for the circuit breaker in the "racked-in" or "racked-out" position.

### MV Connection

The customer connection is easily carried out from the back of M1 and M2 cassettes using the upper and lower bushings.

PE50194

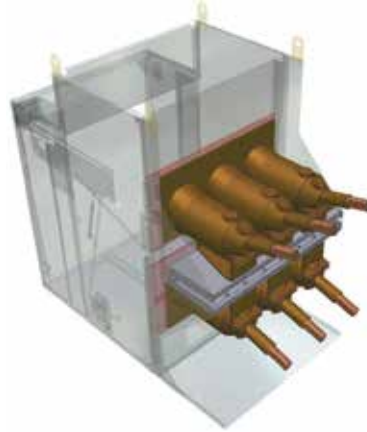

*MV connection with M1 cassette*

PE50195

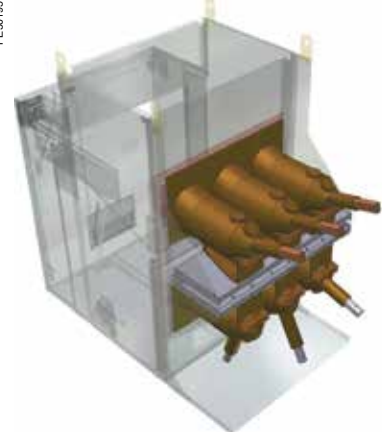

*MV connection with M2 cassette*

### LV connection

With the withdrawable circuit breaker, LV wiring uses an LV connector with:

- the moving part (male Harting socket) at the end of a flexible cable, entirely connected to the control mechanism terminal via a bellow
- the fixed part (female Harting socket) compatible with the male part mounted on the top inside part of the cassette.

### Interlocking function

In conformity with standard IEC 62271-200, an interlocking function prohibits:

- racking-in when the LV connector is not connected
- disconnection of the LV connector if the circuit breaker is in the racked-in position.

PE50197



*LV plug connection*

# Description of functions

## GMH stored energy operating mechanism

### Wiring diagram

023388



#### Operation of the electrical GMH stored energy mechanism

This gives the device an opening and closing speed that is independent of the operator whether the order is electrical or manual.

The electrical control mechanism carries out reclosing cycles and is automatically recharged by a geared motor each time after closing.

#### It consists of:

- the stored energy operating mechanism which stores in springs the energy required to open and close the device
- a manual lever arming device for the springs
- an electrical arming device with a motor to automatically rearm the control mechanism as soon as the circuit breaker is closed (optional)
- manual push-button controls on the front face of the circuit breaker (red and black)
- an electrical remote-closing device comprising a release and an anti-pumping relay.
- an electrical opening device comprising one or several releases of the following type:
  - shunt opening
  - undervoltage
  - Mitop, low energy release.
- an operation counter
- an open/closed position indicator with a mechanical indicator (black and white)
- an "armed" control mechanism status indicator with a mechanical indicator and an electrical contact (optional)
- a block of 14 auxiliary contacts, available according to the wiring layout used
- a pressure switch contact activated by a drop in gas pressure (optional: single or double threshold pressure switch).

#### Wiring diagram (principle)

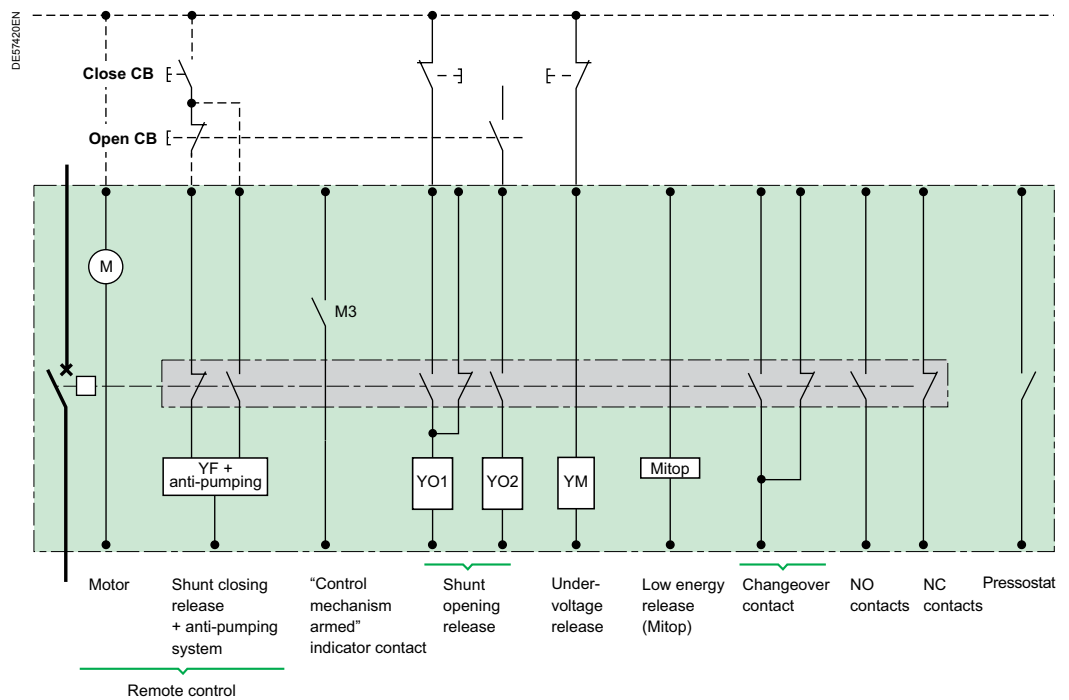

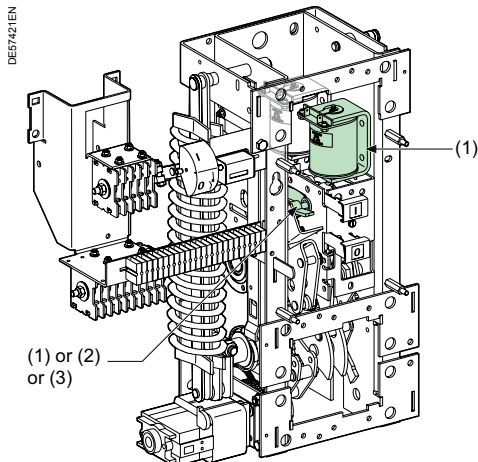

Operating mechanism

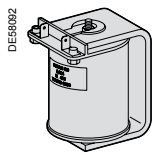

Shunt opening release (1)

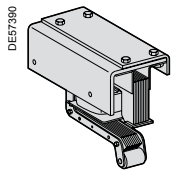

Undervoltage release (2)

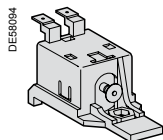

Low energy release (3)

### Composition

The opening circuit can be produced using the following components:

- a shunt opening release (on energizing) (YO1)
- a second shunt opening release (on energizing) (YO2)
- undervoltage release (YM)
- low energy release (Mitop).

**Note:** see the table of the releases' combinations page "Order form".

### Shunt opening release (YO1 and YO2)

Energizing this unit causes instant opening of the circuit breaker.

#### Characteristics

Power supply	See "Order form" page	
Threshold	V AC	0.85 to 1.1 Ur
	V DC	0.7 to 1.1 Ur
Consumption	V AC	160 VA
	V DC	50 W

### Undervoltage release (YM)

This release unit causes the systematic opening of the circuit breaker when its supply voltage drops below a value less than 35% of the rated voltage, even if this drop is slow and gradual. It can open the circuit breaker between 35% and 70% of its rated voltage. If the release unit is not supplied power, manual or electrical closing of the circuit breaker is impossible. Closing of the circuit breaker is compulsory when the supply voltage of the release unit reaches 85% of its rated voltage.

#### Characteristics

Power supply	See "Order form" page		
Threshold	Opening	0.35 to 0.7 Ur	
	Closing	0.85 Ur	
Consumption	Triggering	V AC	400 VA
		V DC	100 W
	Latched	V AC	100 VA
		V DC	10 W

### Low energy release (Mitop)

This specific release unit comprises a low consumption unit.

#### Characteristics

Power supply	Direct current
Threshold	0.04 A < I < 0.12 A

Any tripping due to the Mitop release unit is momentarily indicated by an SDE type changeover contact (option).

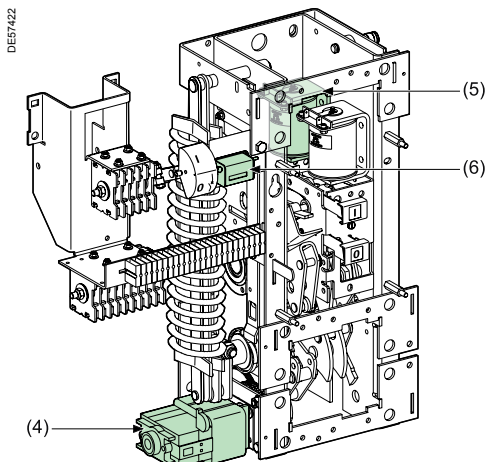

Operating mechanism

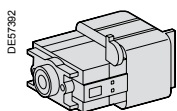

Electrical motor (4)

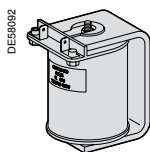

Shunt closing release (5)

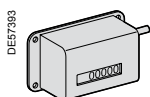

Operation counter (6)

### Function

Remote control enables the remote opening and closing of the circuit breaker.

### Composition

The remote control mechanism comprises:

- an electrical motor with gearing
- a shunt closing release (YF) combined with an anti-pumping device
- an operation counter.

### Electrical motor (M)

The electrical motor carries out the automatic rearming of the stored energy unit as soon as the circuit breaker is closed. This allows the instant reclosing of the device after opening. The arming lever is only used as a backup operating mechanism in the case of the absence of the auxiliary power supply. The M3 contact indicates the end of arming operations.

#### Characteristics

Power supply	See "Order form" page	
Threshold	V AC/V DC	0.85 to 1.1 Ur
Consumption	V AC	380 VA
	V DC	380 W

### Shunt closing release (YF)

This release allows the remote closing of the circuit breaker when the operating mechanism is armed.

#### Characteristics

Power supply	See "Order form" page	
Threshold	V AC	0.85 to 1.1 Ur
	V DC	0.85 to 1.1 Ur
Consumption	V AC	160 VA
	V DC	50 W

The shunt closing release is combined with an anti-pumping relay that enables priority to be given to opening in the case of a permanent closing order. This thus avoids the device being caught in an uncontrolled opening-closing cycle.

### Operation counter

The operation counter is visible on the front panel.

It displays the number of switching cycles (CO) that the device has carried out.

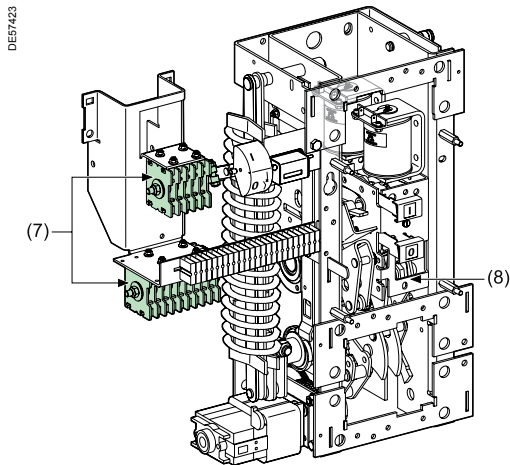

Operating mechanism

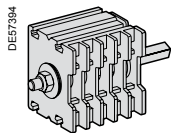

Auxiliary contacts (7)

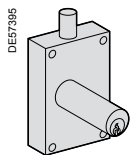

Keylocking kit (8)

### “Open/closed” auxiliary contacts

The number of contacts available depends on the options chosen on the operating mechanism.

In the basic configuration, the circuit breaker’s operating mechanism comprises a total of:

- 5 normally closed contacts (NC)
- 5 normally open contacts (NO)
- 1 changeover contact (CHG).

The usage procedure for auxiliary contacts is given in the following table:

Options	NC contact	NO contact
Shunt opening release (each one) YO1/YO2	0	1
Undervoltage release YM	0	0
Low energy release (Mitop)	0	0

In order to know the final number of available contacts, you must deduct the total number of contacts included in the circuit breaker (5 NC + 5 NO + 1 CHG), the number of contacts used given in the table above.

**E.g.:** a circuit breaker equipped with a remote control and a shunt trip unit has the following available contacts:

5 NC + 4 NO + 1 CHG.

With a undervoltage release instead of the shunt trip, this circuit breaker would have the following available contacts:

5 NC + 5 NO + 1 CHG.

Shunt opening release combination				
	1st release	Shunt opening release YO1	Undervoltage release YM	Mitop
<b>2nd release</b>				
<b>Without</b>		5NC + 4NO + 1CHG	5NC + 5NO + 1CHG	
<b>Shunt opening release YO2</b>		5NC + 3NO + 1CHG	5NC + 4NO + 1CHG	5NC + 4NO + 1CHG
<b>Undervoltage release YM</b>		5NC + 4NO + 1CHG		5NC + 5NO + 1CHG
<b>Mitop</b>		5NC + 4NO + 1CHG	5NC + 5NO + 1CHG	

### Locking the circuit breaker in the “open” position

This key-operated device allows the circuit breaker to be locked in the “open” position. The circuit breaker is locked in the open position by blocking the opening push button in the “engaged” position.

Locking is achieved using a Profalux or Ronis captive key type keylock.

This table describes the safety functions available on the SF circuit breaker withdrawable version.

**How to use the table**

Each of the boxes describes the functional status of each circuit breaker position and the associated parts:

- Possible status
- Possible status, impossible operation
- Impossible status

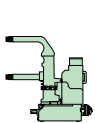
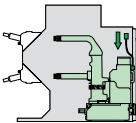
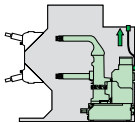
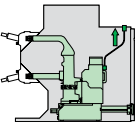
Parts	Circuit breaker positions						
		Insertion → Extraction ←			Racking-in → Racking-out ←		
	Removed		Disconnected	Test position		Service	
1 - Cassette		Fool-proof protection (1)					
		No opening shutters					
		Shutters padlocking possible					
2 - LV plug	Disconnected			No door closing			
	Connected				No unplugging (4)		
3 - Circuit breaker	Closed		Auto-discharge function (2)	No racking-in		No racking-out	
	Open				No closing		
		Open position circuit breaker locking available (2)					
4 - Switchboard door	Open			No racking-in			
	Closed				No door opening (3)		

(1) This protection mechanism ensures that the performance levels of the circuit breaker correspond with those of the cassette..

(2) Option.

(3) Interlocking device to be fitted to the cubicle door.

(4) Because the door is closed.

## Basic withdrawable unit

### SF F400/M1

#### Dimensions and weights

	1250 A	2500/3000 A	
Dimensions (mm)	A	738	752
	B	540	533
	C	2030	2030
	D	36	40
Weight (kg)	750	850	

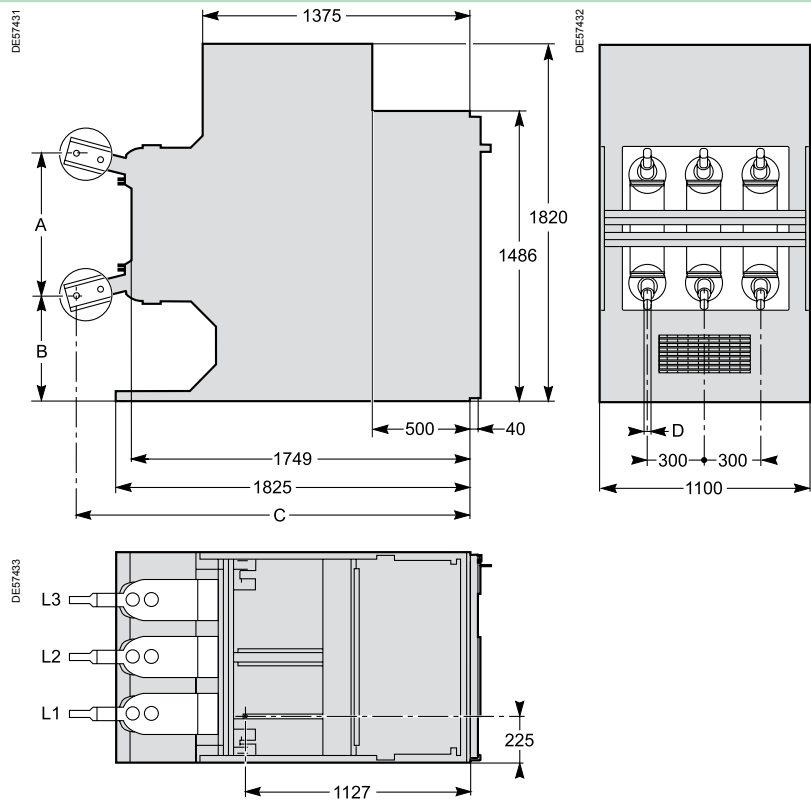

### SF F400/M2

#### Dimensions and weights

	1250 A	2500 A	
Dimensions (mm)	A	1278	1285
	C	2030	2030
	D	36	40
	Weight (kg)	750	850

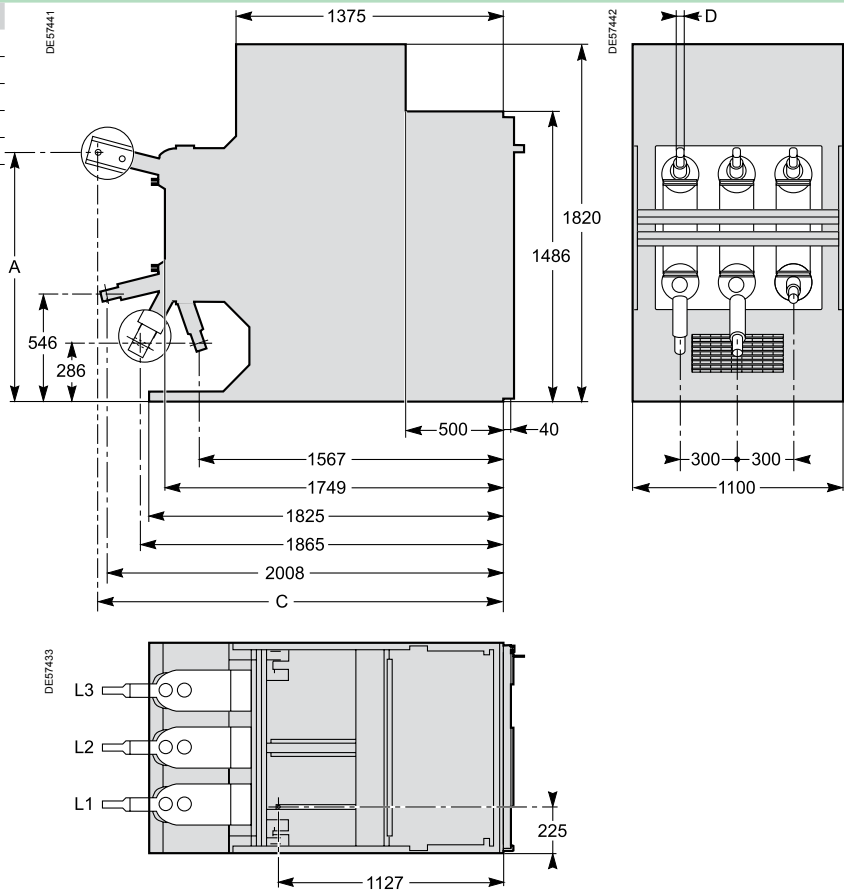

**Connection**

**SF F400/M1**

1250 A

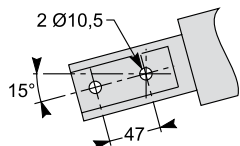
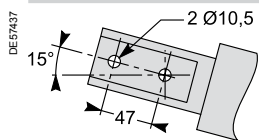

2500/3000 A

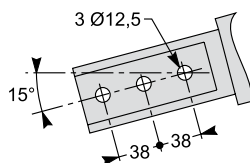
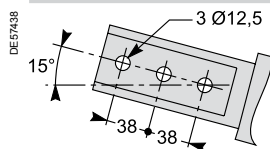

**SF F400/M2**

1250 A

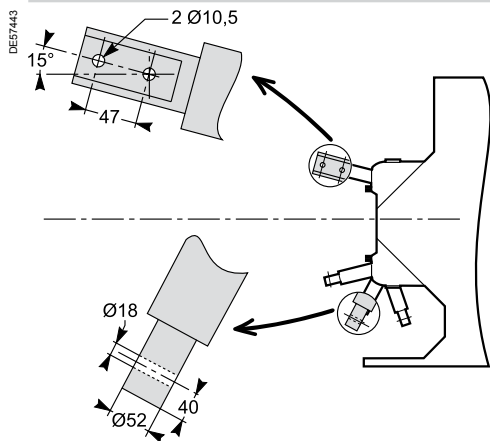

2500 A

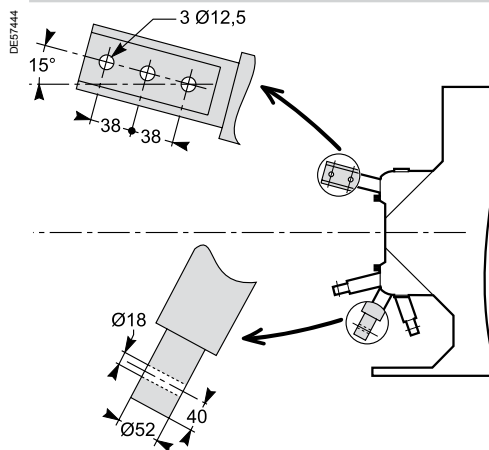

Only one of the boxes (ticked  or filled ) by the needed value) have to be considered between each horizontal line.  
Green box  corresponds to none priced functions.

<b>Basic withdrawable circuit breaker</b>		Quantity	<input type="text"/>
Rated voltage $U_r$		(kV)	<input type="text"/>
Impulse voltage $U_p$		(kVbil)	<input type="text"/>
Short-circuit current $I_{sc}$		(kA)	<input type="text"/>
Rated current $I_r$		(A)	<input type="text"/>
Frequency	50 Hz <input checked="" type="checkbox"/>	60 Hz	<input checked="" type="checkbox"/>
Pressure switch	1 threshold <input checked="" type="checkbox"/>	2 thresholds	<input checked="" type="checkbox"/>
<b>Colour for push buttons and indicators</b>			
Push buttons open/close:		Red/black	<input checked="" type="checkbox"/>
Indicator open/close:		Black/white	<input checked="" type="checkbox"/>
Operating mechanism charged/discharged:		White/yellow	<input checked="" type="checkbox"/>

### Circuit breaker options

**1st opening release** (see possible choices in combination table below)

Shunt opening release **YO1**

24 Vdc	<input checked="" type="checkbox"/>	60 Vdc	<input checked="" type="checkbox"/>	220 Vdc	<input checked="" type="checkbox"/>	220 Vac (50 Hz)	<input checked="" type="checkbox"/>
30 Vdc	<input checked="" type="checkbox"/>	110 Vdc	<input checked="" type="checkbox"/>	48 Vac (50 Hz)	<input checked="" type="checkbox"/>	120 Vac (60 Hz)	<input checked="" type="checkbox"/>
48 Vdc	<input checked="" type="checkbox"/>	125 Vdc	<input checked="" type="checkbox"/>	110 Vac (50 Hz)	<input checked="" type="checkbox"/>	240 Vac (60 Hz)	<input checked="" type="checkbox"/>

**2nd opening release** (see possible choices in combination table below)

Shunt opening release **YO2**

24 Vdc	<input type="checkbox"/>	60 Vdc	<input type="checkbox"/>	220 Vdc	<input type="checkbox"/>	220 Vac (50 Hz)	<input type="checkbox"/>
30 Vdc	<input type="checkbox"/>	110 Vdc	<input type="checkbox"/>	48 Vac (50 Hz)	<input type="checkbox"/>	120 Vac (60 Hz)	<input type="checkbox"/>
48 Vdc	<input type="checkbox"/>	125 Vdc	<input type="checkbox"/>	110 Vac (50 Hz)	<input type="checkbox"/>	240 Vac (60 Hz)	<input type="checkbox"/>

Undervoltage release **YM**

24 Vdc	<input type="checkbox"/>	60 Vdc	<input type="checkbox"/>	220 Vdc	<input type="checkbox"/>	220 Vac (50 Hz)	<input type="checkbox"/>
30 Vdc	<input type="checkbox"/>	110 Vdc	<input type="checkbox"/>	48 Vac (50 Hz)	<input type="checkbox"/>	120 Vac (60 Hz)	<input type="checkbox"/>
48 Vdc	<input type="checkbox"/>	125 Vdc	<input type="checkbox"/>	110 Vac (50 Hz)	<input type="checkbox"/>	240 Vac (60 Hz)	<input type="checkbox"/>

Mitop (not available with seismic version)

Without contact  With contact

**Remote control**

Electrical motor **M**

24...32 Vdc	<input checked="" type="checkbox"/>	110...127 Vdc/ac	<input type="checkbox"/>
48...60 Vdc/ac	<input checked="" type="checkbox"/>	220...250 Vdc/ac	<input checked="" type="checkbox"/>

Shunt closing release **YF**

24 Vdc	<input checked="" type="checkbox"/>	60 Vdc	<input checked="" type="checkbox"/>	220 Vdc	<input checked="" type="checkbox"/>	220 Vac (50 Hz)	<input checked="" type="checkbox"/>
30 Vdc	<input checked="" type="checkbox"/>	110 Vdc	<input checked="" type="checkbox"/>	48 Vac (50 Hz)	<input checked="" type="checkbox"/>	120 Vac (60 Hz)	<input checked="" type="checkbox"/>
48 Vdc	<input checked="" type="checkbox"/>	125 Vdc	<input checked="" type="checkbox"/>	110 Vac (50 Hz)	<input checked="" type="checkbox"/>	240 Vac (60 Hz)	<input checked="" type="checkbox"/>

Locking C.B. in open position	Ronis	<input type="checkbox"/>	Profalux	<input type="checkbox"/>
Leaflets language	French	<input checked="" type="checkbox"/>	English	<input checked="" type="checkbox"/>

**M1/M2 cassettes**

MC cassette type	M1	<input type="checkbox"/>	M2	<input type="checkbox"/>
Rated short-circuit current $I_{sc}$			$\leq 40$ kA	<input type="checkbox"/>
Rated current $I_r$	1250 A	<input type="checkbox"/>	2500/3000 A	<input type="checkbox"/>

**M1/M2 cassettes accessories**

Racked-in/out position contact	4 NO, 4 NC	<input type="checkbox"/>
Extra handle	Quantity	<input type="text"/>

*Releases combinations table*

Shunt opening releases <b>YO1/YO2</b>	1	<input checked="" type="checkbox"/>	2	<input checked="" type="checkbox"/>	1	<input checked="" type="checkbox"/>	1	<input checked="" type="checkbox"/>	2	<input checked="" type="checkbox"/>		
Undervoltage release <b>YM</b>		1	<input checked="" type="checkbox"/>		1	<input checked="" type="checkbox"/>		1	<input checked="" type="checkbox"/>		1	<input checked="" type="checkbox"/>
Mitop						1	<input checked="" type="checkbox"/>		1	<input checked="" type="checkbox"/>		



---

**Schneider Electric Industries SAS**

35, rue Joseph Monier  
CS 30323  
F - 92506 Rueil Malmaison Cedex

RCS Nanterre 954 503 439  
Capital social 896 313 776 €  
[www.schneider-electric.com](http://www.schneider-electric.com)

AMTED304010EN

As standards, specifications and designs change from time to time, please ask for confirmation of the information given in this publication.



*This document has been printed  
on ecological paper*

Publishing: Schneider Electric Industries SAS  
Design: Schneider Electric Industries SAS  
Printing: Altavia Connexion - Made in France



02-2014